



E-Series HV

ELECTROLYZER RECTIFIER BASED ON IGBT TECHNOLOGY WITH A WIDER DC VOLTAGE RANGE

Great DC current density with a wider voltage range

The INGECON® H2 E-Series HV rectifiers feature a great DC current density with up to 6,714 A and a wider DC voltage range up to 1,500 Vdc. Thus, it is the best solution to feed electrolyzers from clean energy sources, especially those electrolyzers with an operation voltage range greater than 1,300 Vdc.

Latest generation electronics

The INGECON® H2 E-Series HV rectifiers are based on Ingeteam's latest-generation IGBT technology, that enables AC-to-DC power conversion with no need of any additional harmonic filters nor STATCOM units, thanks to Ingeteam's THD (total harmonic distortion) lower than 3%.

These rectifiers feature a very low power consumption thanks to an efficient power supply electronic board.

Furthermore, the hardware of the control unit allows accurate measurements and very reliable protections.

Flexible configuration

These rectifiers feature several power stacks, allowing to connect the DC output to one or several electrolyzers working independently.

Improved medium voltage integration

These rectifiers have been designed in order to facilitate a direct close-coupled connection with the MV/LV transformer. Thus, Ingeteam offers an all-in-one power station that is capable to perform MV to LV conversion while also converting from AC to DC.

Liquid Cooling System (LCS)

The LCS is a closed circuit supplied totally filled and purged, equipped with fast connectors with an anti-dripping system, so it offers zero risk of particle entrance. It has been designed to avoid siphons in order to easily purge it if necessary. The coolant used is a biodegradable glycol water mixture. There is no need of emptying the LCS in order to replace the phases, nor the sensors.

H2 E-Series HV Electrolyzer rectifier based on IGBT technology with a wider DC voltage range

Long-lasting design

The rectifiers have been designed to guarantee a long life expectancy, as demonstrated by the stress tests they are subjected to. Standard 2-year warranty, extendable upon request.

Ease of maintenance

All the elements can be removed or replaced directly from the rectifier's front sides, thanks to its new design.

Easy to operate

The INGECON® H2 E-Series HV rectifiers feature a number of LEDs to show the

rectifier operating status with warning lights to indicate any incidents. All this helps to simplify and facilitate maintenance tasks.

Enhanced protection system

The rectifier is securely connected to the electrolyser using a pre-charge system that smoothly controls the DC current during the electrolyser start-up. Additionally, as an option, the converter can include a flushing system to ensure safe access to the electrolyser for O&M works.

Monitoring and communication

Wi-Fi and dual Ethernet communications supplied as standard. Also included at no extra cost the monitoring applications to record and monitor the rectifier's internal operating variables through the Internet (alarms, real time production, etc.). Two Ethernet communication ports available (one for monitoring and one for plant controlling), allowing fast and simultaneous plant control.

Protections

- DC Reverse polarity.
- Short-circuits and overloads at the output. Insulation failure DC.
- Lightning induced AC surge arresters, type II.
- Motorized DC isolator.
- Motorized AC circuit breaker.
- Hardware protection via firmware.
- Additional protection for the power stack, liquid cooled, IP65 rated and air cooled by a closed loop.
- Integrated stack discharge system.

Optional accessories

- Lightning induced AC surge arresters, type I+II.
- Electrolyser discharge system.

Liquid cooling system

- LCS to refrigerate the IGBTs.
- More optimized component usage: greater thermal stability.
- Less moving components: lower power consumption and less maintenance works.
- No risk of particle entrance.
- C5H anti-corrosive rating with stainless steel components.
- LCS is used in many industries. Thus, it is very reliable, as its components are subject to many validation tests.
- Fast connectors with anti-dripping system Biodegradable glycol water mixture.
- No need of emptying the LCS in order to replace the phases, nor the sensors.

Advantages

- Higher current density.
- Latest generation electronics.
- More efficient electronic protection.
- Enhanced performance.
- Easier maintenance thanks to its new design and enclosure.
- Lightweight spares.
- Components easily replaceable.

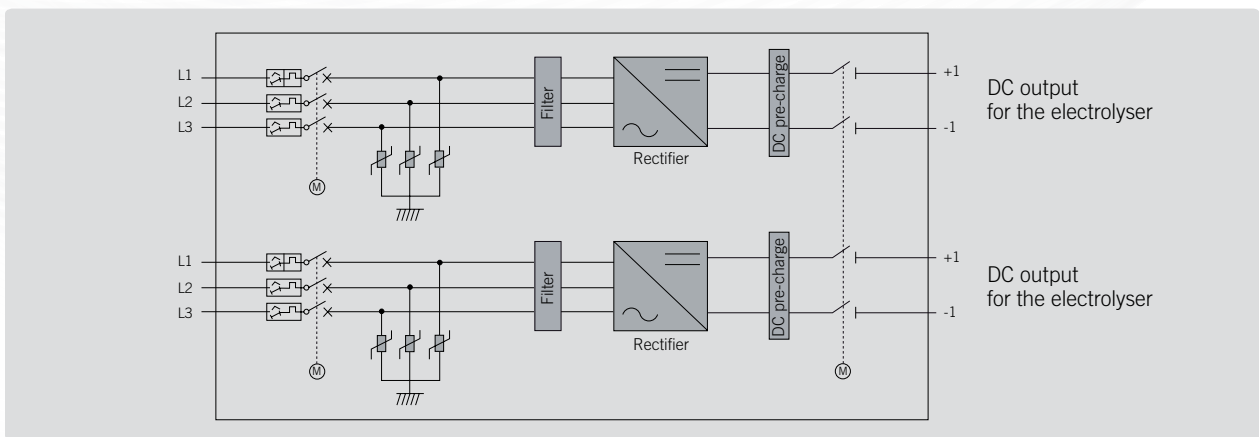

Size and weight (mm)

5,500 kg

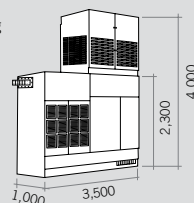

INGECON® H2 E6000 HV

OUTPUT (DC)

Voltage Range ⁽¹⁾	350 - 1,500 V
Maximum voltage	1,500 V
Rated current ⁽²⁾	6,000 A
Maximum current	6,497 A
DC current ripple ⁽³⁾	<1%
Type of connection	Connection to copper bars
Number of outputs ⁽⁴⁾	2

OUTPUT PROTECTION

DC Pre-charge	Protection system to control the DC current during the electrolyser start-up
DC switch	Motorized DC load break disconnect
Other protections	Insulation failure monitoring / Electrolyser stack discharge system

INPUT (AC)

Current @1,500 Vdc (30 °C / 50 °C)	5,128 A / 4,142 A
Rated voltage ⁽¹⁾	600 - 840 V IT System
Frequency	50 / 60 Hz
Power Factor adjustable	Yes, 0-1 (leading / lagging)
THD (Total Harmonic Distortion) ⁽³⁾	<3%

INPUT PROTECTIONS

Overvoltage protections	Type II surge arresters (type I+II Surge arresters)
AC breaker	Motorized AC circuit breaker
Other protections	AC short circuits and overloads

FEATURES

Maximum efficiency	98.9%
Euroefficiency	98.5%
Max. consumption aux. services	15,000 W
Stand-by consumption	370 W

GENERAL INFORMATION

Operating temperature	-20 °C to +60 °C
Relative humidity (non-condensing)	0 - 100%
Protection class	IP65 ⁽⁵⁾
Corrosion protection	External corrosion protection
Maximum altitude	4,500 m (for installations beyond 1,000 m, please contact Ingeteam's hydrogen sales department)
Cooling system	Liquid cooling system and forced air cooling system with temperature control (400V 3 phase + neutral power supply, 50/60 Hz)
Air flow range	0 - 36,000 m ³ /h
Average air flow	24,000 m ³ /h
Acoustic emission (100% / 50% load)	57 dB(A) at 10m / 49.7 dB(A) at 10m
Marking	CE
Compliance with	NFPA70, CSA C22.1
Certification	IEC 62477-1, UL1741 Ed.3, CSA C22.2 No 107.1, IEC 60529, CISPR11 (group 1 class A in-situ measurements), IEC 61000-6-2 (in-situ measurements), IEC 60068-2-1, IEC 60068-2-2, IEC 60068-2-14, IEC 60068-2-68

Notes

- (1) For lower voltage values, please contact Ingeteam.
(2) This rated current has been calculated for Vd_{min}=720 V; Vd_{max}=900 V; ambient temperature 35 °C.
(3) For P_{out}>25% of the rated power and voltage in accordance with IEC 61000-3-4.
(4) These outputs could be connected to the same electrolyser or to two different electrolysers.
(5) Except for the LC filter and the air-water heat exchanger, that are IP54.

EUROPE

Ingeteam Power Technology, S.A.
Avda. Ciudad de la Innovación, 13
31621 Sarriguren (Navarra) - Spain
Tel.: +34 948 288 000
Fax: +34 948 288 001
e-mail: solar.energy@ingeteam.com
bess.energy@ingeteam.com

Ingeteam S.A.
Parque Tecnológico de Bizkaia
Edificio 106
48170, Zamudio (Bizkaia) – Spain
Tel.: +34 944 039 710

Ingeteam S.r.l.
Via Emilia Ponente, 232
48014 Castel Bolognese (RA) - Italy
Tel.: +39 0546 651 490
Fax: +39 054 665 5391
e-mail: italia.energy@ingeteam.com

Ingeteam SAS
140 Rue Carmin - Le Naurouze B
31670 Labège - France
Tel.: +33 (0)5 61 25 00 00
Fax: +33 (0)5 61 25 00 11
e-mail: france@ingeteam.com

Ingeteam, a.s.
Technologická 371/1
70800 Ostrava - Pustkovec
Czech Republic
Tel.: +420 597 476 820
Fax: +420 59 732 6899
e-mail: czech@ingeteam.com

Ingeteam GmbH
Grand Bateau – Zollhof 6
D-40221 – Düsseldorf, Germany
Tel.: +49 (0) 211 78177950
e-mail: deutschland@ingeteam.com

Ingeteam Poland Spzoo
Ul. Koszykowa 60/62 m 39
00-673, Warsaw, Poland
Tel.: (+48) 22 821 99 30
e-mail: polska@ingeteam.com

Ingeteam LTD.
1st Floor, Midas House, 62 Goldsworth Road,
Woking, Surrey GU21 6LQ - United Kingdom
Tel.: +44 (0) 141 488 5290

NORTH AMERICA

Ingeteam Inc.
3550 W. Canal St.
Milwaukee, WI 53208 - USA
Tel.: +1 (414) 934 4100 / +1 (855) 821 7190
Fax: +1 (414) 342 0736
e-mail: usa@ingeteam.com

Ingeteam Power Technology S de RL de CV
Av. Ejercito Nacional Mexicano 351, Chapultepec
Morales, Granada, Manuel Hidalgo
CP: 11520
Ciudad de México, México
Tel.: (+52) 55 6586 9930
e-mail: proveedores.ipm@ingeteam.com

SOUTH AMERICA

Ingeteam Ltda.
Rua Estácio de Sá, 560
Santa Genebra
Campinas - SP
CEP: 13080-010; São Paulo - Brazil
Tel.: (+55) 19 30 37 37 73
e-mail: brazil@ingeteam.com

Ingeteam Chile SpA
Balmoral n.º 309, Piso 10º, Oficina 1008,
7561282 Las Condes
Santiago, Chile
Tel.: (+56) 229 253 825
e-mail: chile@ingeteam.com

ASIA

Ingeteam Power Technology Shanghai, Co. Ltd.
Room 2606-F, No.360 South Pudong Road
China (Shanghai) pilot free trade zone
C.P 200120
Tel.: +86 139 1622 4886
e-mail: liu.yimin@ingeteam.com

Ingeteam India Pvt. Ltd.
Survey No. 111/1-111/3 & 111/5-111/7,
Village No.155, Mambakkam Village,
Chennai - Bangalore Main Road,
Sriperumbudur Taluk,
Kancheepuram District - 602106,
Tamilnadu, India

Ingeteam Power Technology S.A. UAE Branch
Al Bateen tower c6 Bainunah 1st floor
Street 34
Abu Dhabi - UAE
Tel.: +971 2 207 6666

Ingeteam Power Technology S.A.
Thailand representative office
100/67 Vongvanij B Building, 22nd floor,
Rama IX Road., HuayKwang,
10320 Bangkok
Te.: +66 22461798
e-mail: Thailand.pga@ingeteam.com

Ingeteam Vietnam CO., LTD
Spaces Building, 28A Tran Hung Dao Street,
Phan Chu Trinh Ward Hoan Kiem District,
Hanoi City, Vietnam

AUSTRALIA

Ingeteam Australia Pty Ltd.
Iaccelerate Centre, Building 239
Innovation Campus, Squires Way
North Wollongong, NSW 2500 - Australia
Tel.: +61 429 111 190
e-mail: australia@ingeteam.com

Ingeteam

www.ingeteam.com