

Ingeteam



INGETEAM RAPID
60E - 90 - 120 - 150 - 180

Installation and Operation Manual

ACA2011IQM01_C
03/2024

Ingeteam Power Technology, S.A. - Energy

Avda. Ciudad de la Innovación, 13
31621 SARRIGUREN (Navarra) - Spain
Tel.: +34 948 28 80 00
Fax.: +34 948 28 80 01
e-mail: electricmobility.energy@ingeteam.com

Service Call Center: +34 948 698 715

The copy, distribution or use of this document or of its content requires written authorisation. Any breach thereof will be reported for damages. All rights reserved including those of patent rights or design registration.

The conformity of the document content with the hardware described has been checked. However, discrepancies may exist. Liability will not be assumed for total concordance. The information contained in this document is regularly reviewed and it is possible that there may be changes in subsequent editions. Other functions may be available which are not covered by this document.

This document may be changed.

Important safety instructions

This section describes the safety warnings and the personal protective equipment and symbols used in the unit.

Safety conditions

General warnings

DANGER

Opening the enclosure does not imply there is no voltage inside.

The risk of electric shock exists even after disconnecting from the grid.

Only qualified personnel may open it, following the instructions in this manual.

It is strictly forbidden to gain access to the inside of the electrical panel through any other point than the access cover provided for this purpose. Always gain access when the unit is voltage-free.

CAUTION

The operations described in the manual may be performed only by qualified personnel.

The status of qualified personnel referred to in this manual will be, as a minimum, that which meets all the standards, regulations and laws regarding safety applicable to the tasks of installing and operating this unit.

The responsibility for designating qualified personnel will always fall to the company to which the personnel belong. It is necessary to decide which workers are suitable or not for carrying out specific work to preserve their safety at the same time as complying with occupational safety legislation.

These companies are responsible for providing appropriate training in electrical equipment to their personnel and for familiarizing them with the contents of this manual.

All applicable safety-related legislation for electrical work must be complied with. Danger of electric shock.

Compliance with the safety instructions set out in this manual or in the suggested legislation does not imply exemption from other specific standards for the installation, place, country or other circumstances that affect the unit.

You must consider the set of conditions listed throughout this document as minimum requirements. It is always preferable to shut off the main power supply. There may be faults in the installation that cause the unwanted return of voltage. Danger of electric shock.

According to basic safety standards, the complete unit must be suitable to protect exposed workers against the risk of direct and indirect contact. In any case the electrical parts of the work equipment must comply with the provisions of the corresponding specific regulations.

According to basic safety standards, the electrical installation shall not entail a fire or explosion risk. Workers must be duly protected against the risk of accidents caused by direct or indirect contact. The electrical installation and protection devices must take into account the voltage, the external conditions and the competence of persons who have access to parts of the installation.

To check the absence of voltage, it is compulsory to use measurement devices with category III-1000 V.

INFO

These instructions must be easily accessible close to the unit and located within reach of all users.

Before installation and start-up, please read these safety instructions and warnings carefully as well as all the warning notices located on the unit. Ensure that all the warnings signs are perfectly legible and that those which are damaged or have disappeared are restored.

Protection against direct contact is by means of the enclosure.

The unit has been tested according to the applicable regulations to comply with the safety requirements, the values for insulation clearances and leakage paths for the voltages used.

Potential hazards for people** DANGER**

Electric shock.

The equipment may remain charged after disconnecting the grid power.

Carefully follow the mandatory steps in the manual for removing the voltage.

Explosion.

There is a very low risk of explosion in very specific cases of malfunction.

The casing will protect people and property from the explosion only if it is correctly closed.

Crushing and joint injuries.

Always follow the indications in the manual on moving and placing the unit.

The weight of this unit can cause serious injury and even death if not handled correctly.

High temperature.

The flow of outlet air can reach high temperatures which can cause injury to anybody exposed to it.

Potential hazards for the equipment** DANGER**

Cooling.

The unit requires particle-free air flow while it is operating.

Keeping the unit in the upright position and the inlets free of obstacles is essential for this air flow to reach the inside.

Do not touch boards or electronic components. The more sensitive components can be damaged or destroyed by static electricity.

Do not disconnect or connect any terminal while the unit is operating. Disconnect and check for absence of voltage first.

With the aim of avoiding premature wear of the screwed joints on the unit's housing panels, removal and installation of the screws must be done manually.

Personal Protective Equipment (PPE)

When working on the unit, use the following safety equipment recommended by Ingeteam as a minimum.

Name	Description
Safety footwear	In compliance with standard <i>UNE-EN-ISO 20345:2012 ANSI Z41.1-1991</i>
Helmet with face shield	In compliance with standard <i>UNE-EN 397:1995, ANSI Z89.1-2014</i> , provided there are elements with voltage directly accessible.
Working clothes	Close-fitting, non-flammable, 100% cotton
Dielectric gloves	In compliance with standard <i>EN 60903:2005 ASTM D 120-87</i>

Tools and / or equipment used in live work must have at least Category III-1100 Volts insulation.

Should the country's regulations demand another kind of personal protection, you should appropriately supplement the equipment recommended by Ingeteam.

Symbols

In the equipment, the following symbols are included.



Electrical danger

Warning of dangerous voltage: this warns of high voltage which could cause serious or fatal injuries and / or damage to the equipment.



Caution, hot surface: this warns of hot surfaces which could cause serious burns.



It is mandatory to read the instruction manual.



Electrical and electronic equipment should not be discarded in the household waste container.

Contents

Important safety instructions	4
Safety conditions.....	4
Personal Protective Equipment (PPE).....	6
Symbols	6
Contents	7
1. About this manual.....	9
1.1. Scope and nomenclature	9
1.2. Recipients.....	10
1.3. Symbols.....	10
2. Unit description	11
2.1. Overview	11
2.2. Models.....	11
2.3. Connectors.....	11
2.3.1. Connectors for DC charging	11
2.3.2. Connectors for AC charging.....	13
2.4. Protection	14
2.5. Accessories equipped as standard	16
2.6. Additional options.....	16
2.7. Acoustic contamination	16
2.8. Electrical diagram of the system.....	17
2.9. Specification table	20
3. Receipt of the unit and storage.....	21
3.1. Reception	21
3.2. Unit identification.....	21
3.3. Transport damage	21
3.4. Storage	21
3.5. Conservation.....	21
4. Transporting and handling the unit	22
4.1. Unpacking	22
4.2. Lifting	22
4.3. Fitting the ring	25
5. Preparation for installing the unit	26
5.1. Environment.....	26
5.2. Environmental conditions	27
5.3. Type of grid	28
5.4. External disconnection device	29
6. Installing the unit	30
6.1. General requirements for installation	30
6.2. Fastening the unit.....	31
7. Connection of accessories.....	35
7.1. Safety instructions for connecting accessories	35
7.2. VISA kit	35
7.3. Connection kit for two cables	36
7.4. External communication interconnection Kit.....	39
7.4.1. Mechanical installation	39
7.4.2. Electrical connection	39
7.5. Repowering kit	40
7.6. Electric vehicle detector	43
7.7. 4G communications kit	45
7.8. Leveling gage kit.....	47
8. Charger power supply connection.....	48
8.1. Safety instructions for the AC connection	48
8.2. Cabling requirements	48
8.3. Connection process	49

9. First connection to the electric grid.....	52
9.1. Unit inspection.....	52
9.1.1. Inspection.....	52
9.1.2. Hermetic sealing of the unit	52
10. Shutting down the unit	53
11. Unit configuration	54
11.1. Local connection	54
11.1.1. Local connection via Ethernet.....	54
11.2. Remote connection	55
12. Operation	56
12.1. Status indication	56
12.2. User interface.....	57
12.3. Charging process	57
12.3.1. Charging process with authentication.....	57
12.3.2. Charging process without authentication	59
12.4. Downloading the receipt (Eichrecht certified units)	59
13. Maintenance	60
13.1. Safety conditions	60
13.2. Condition of hoses and charging connectors	60
13.3. Condition of the housing.....	60
13.4. Condition of cables and terminals.....	60
13.5. Cleaning or replacing filters	61
14. Waste handling	62

1. About this manual

The purpose of this manual is to describe the INGETEAM RAPID 60E, 90, 120, 150 and 180 units and to provide appropriate information for their correct reception, installation, start-up, maintenance and operation.

This manual contains important information that should be taken into account during the installation, operation and maintenance of the unit. Keep this manual throughout the unit's useful life.

1.1. Scope and nomenclature

This manual is applicable to the following units:

Complete name	Abbreviation
INGETEAM RAPID XX Trio CCS	Trio CCS
INGETEAM RAPID XX Trio CCS+CHA	Trio CCS+CHA
INGETEAM RAPID XX Duo CCS	Duo CCS
INGETEAM RAPID XX Duo CCS+CHA	Duo CCS+CHA
INGETEAM RAPID XX One	One
INGETEAM RAPID XX One+	One+

Note: XX is equivalent to the power of the unit

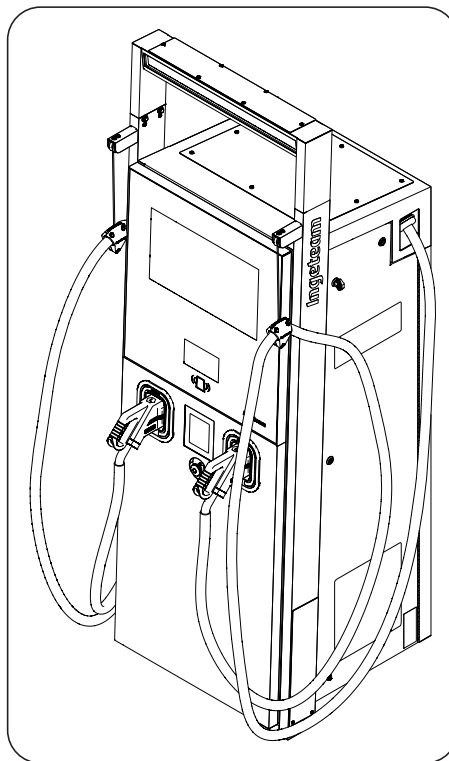

Fig. 1 Exterior view of the unit

1.2. Recipients

This document is intended for qualified personnel.

The status of qualified personnel referred to in this manual will be, as a minimum, that which meets all the standards, regulations and laws regarding safety applicable to the tasks of installing and operating this unit.

The responsibility for designating qualified personnel will always fall to the company to which the personnel belong. It is necessary to decide which workers are suitable or not for carrying out specific work to preserve their safety at the same time as complying with occupational safety legislation.

These companies are responsible for providing appropriate training in electrical equipment to their personnel and for familiarizing them with the contents of this manual.

1.3. Symbols

Throughout this manual we include warnings to highlight certain information. Relative to the nature of the text, there are three types of warnings:



This indicates a hazard to personnel or the charger.



Indicates importance.



Additional information or references to other parts of the document or documents.

2. Unit description

2.1. Overview

INGETEAM RAPID chargers are a multi-standard fast charging model designed for the fast charging requirements of the latest electric vehicles, allowing to recover up to 100 km of range in no more than 8 minutes.

The different models of the INGETEAM RAPID are compatible with mode 4 with standards CHAdeMO and CCS1/CCS2 in DC and with mode 3 with AC Type 2 in AC.

They have been designed for use outdoors and may be installed in locations with unrestricted access. Given its nature, this is a fixed, freestanding unit classified as Class I equipment.

2.2. Models

The INGETEAM RAPID chargers have several models with the following connector types available:

	Connector type		
	DC		AC
	CCS1/CCS2	CHAdeMO	AC Type 2
INGETEAM RAPID XX Trio CCS	●	○	●
INGETEAM RAPID XX Trio CCS+CHA	●	●	●
INGETEAM RAPID XX Duo CCS	●	○	○
INGETEAM RAPID XX Duo CCS+CHA	●	●	○
INGETEAM RAPID XX One	●	○	○
INGETEAM RAPID XX One+	●	○	●

● Equipped // ○ Not equipped

These models are designed to remain connected to the public AC grid. They all generate DC current and the Trio models also generate AC current.

2.3. Connectors

2.3.1. Connectors for DC charging

The following connectors are based on DC fast charging standards for electric vehicles.

CCS1

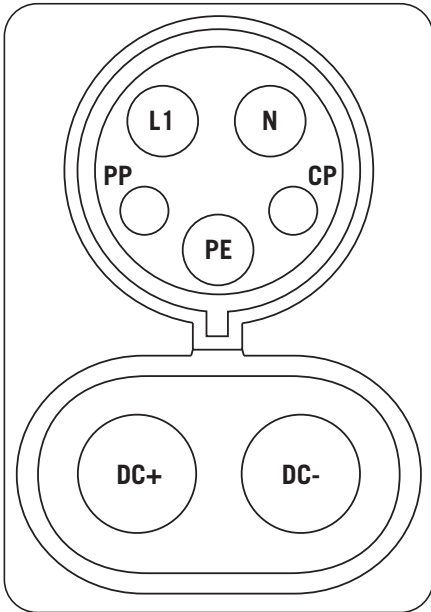

- L1: Phase 1
- N: Neutral
- PP: *Proximity Pilot*, pre-insertion signal
- CP: *Control Pilot*, post-insertion signal
- PE: *Protective Earth*
- DC+
- DC-

CCS2

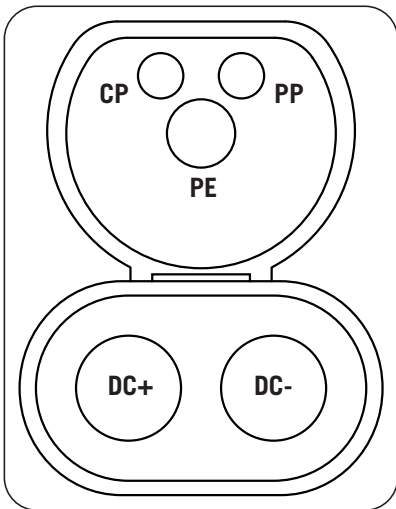

- PP: *Proximity Pilot*, pre-insertion signal
- CP: *Control Pilot*, post-insertion signal
- PE: *Protective Earth*
- DC+
- DC-

CHAdeMO

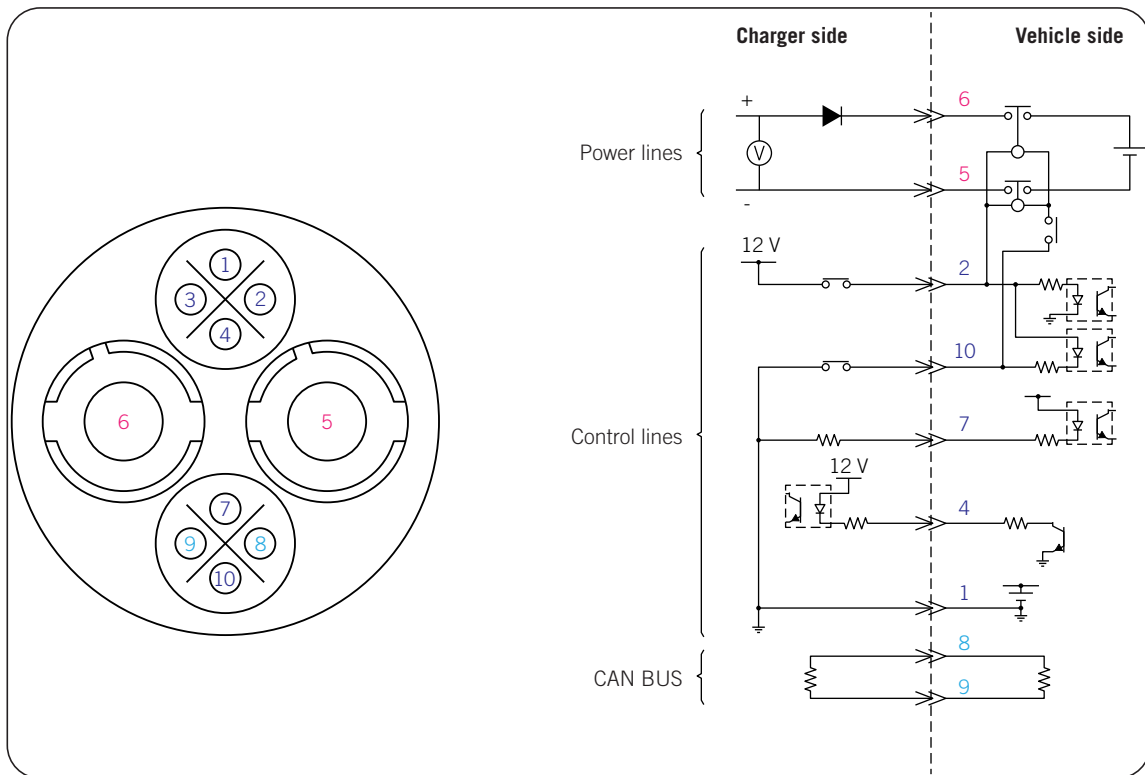

2.3.2. Connectors for AC charging

The following connector is based on AC fast charging standards for electric vehicles.

IEC 62196-2 AC Type 2

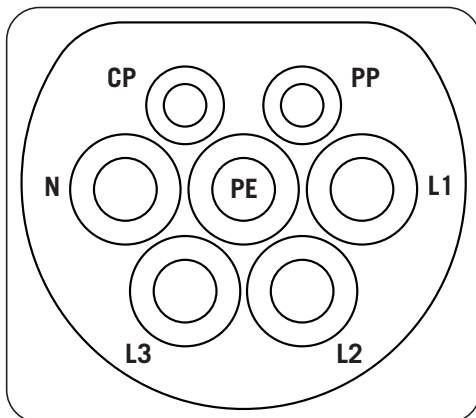

- PP: *Proximity Pilot*, pre-insertion signal
- CP: *Control Pilot*, post-insertion signal
- PE: *Protective Earth*
- N: Neutral
- L1: Phase 1
- L2: Phase 2
- L3: Phase 3

2.4. Protection

This charging station has several protections, as described below:

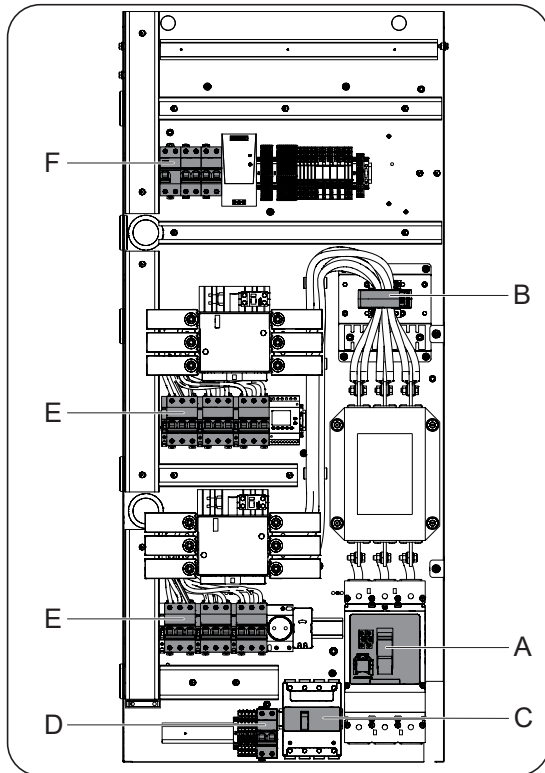

Arrangement of protection elements ONE+ units

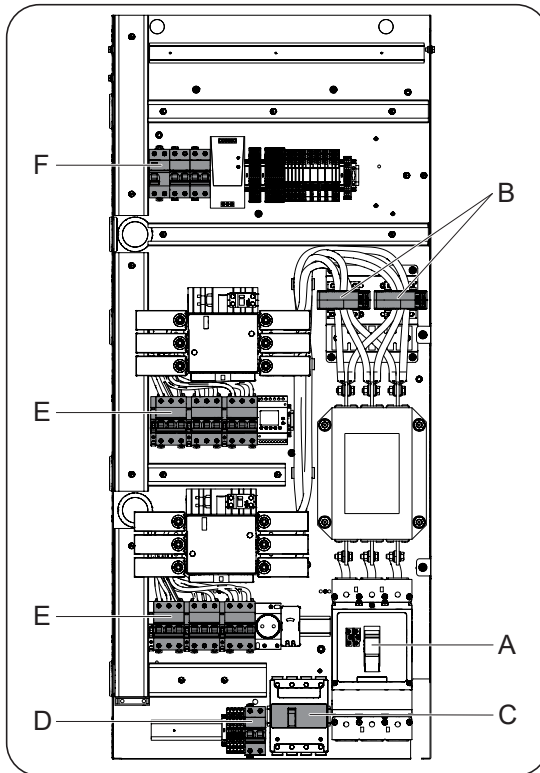

Arrangement of protection elements TRIO units

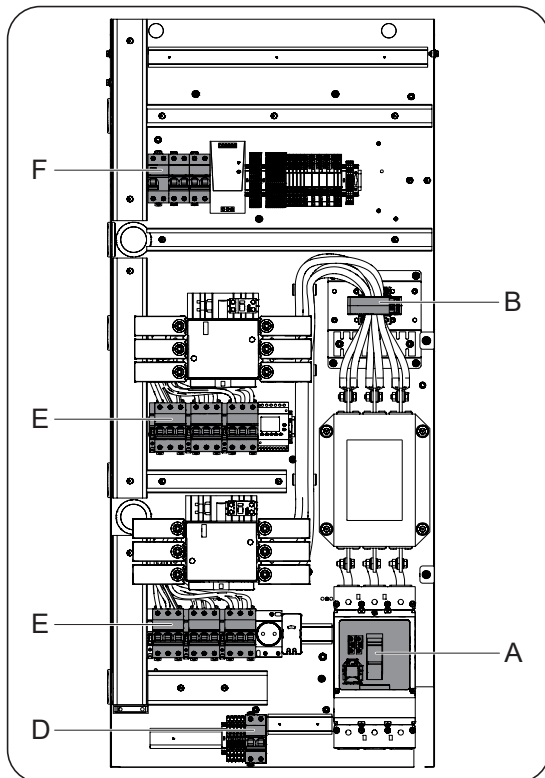

Arrangement of protection elements ONE units

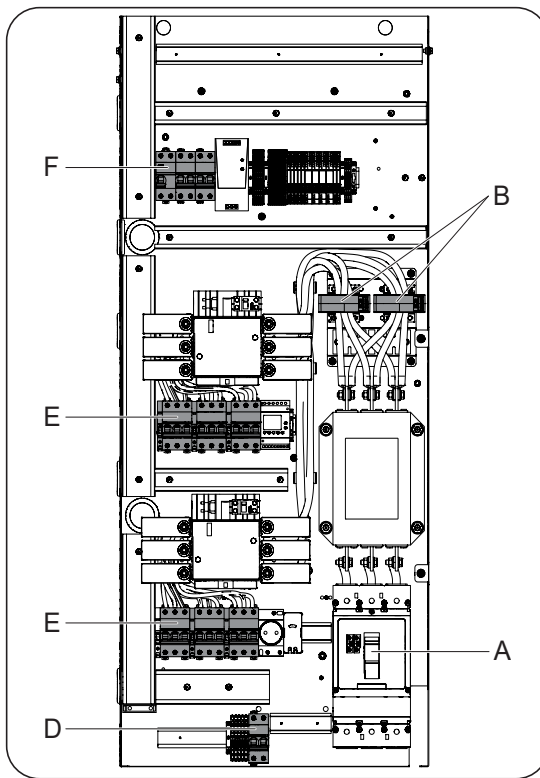

Arrangement of protection elements DUO units

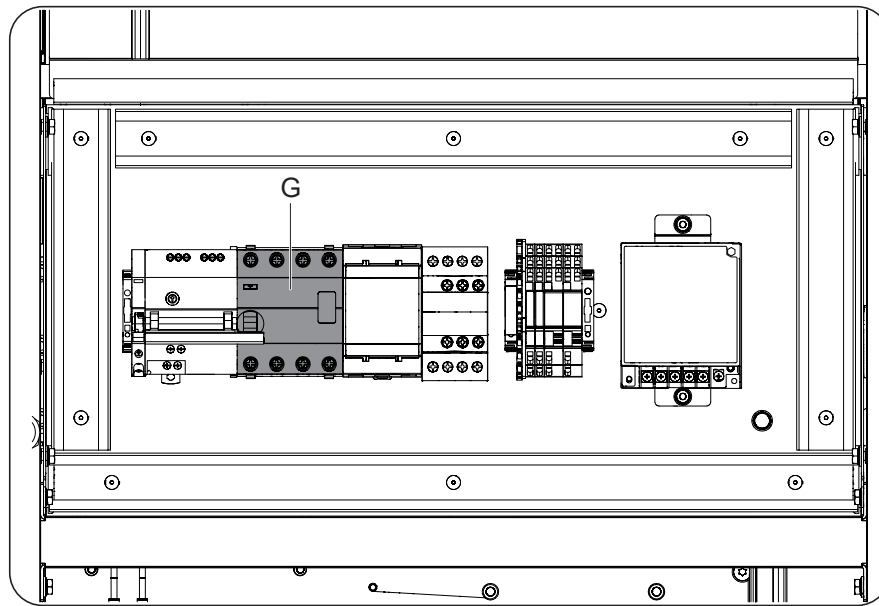

Fig. 3 Arrangement of protection elements and AC charging control

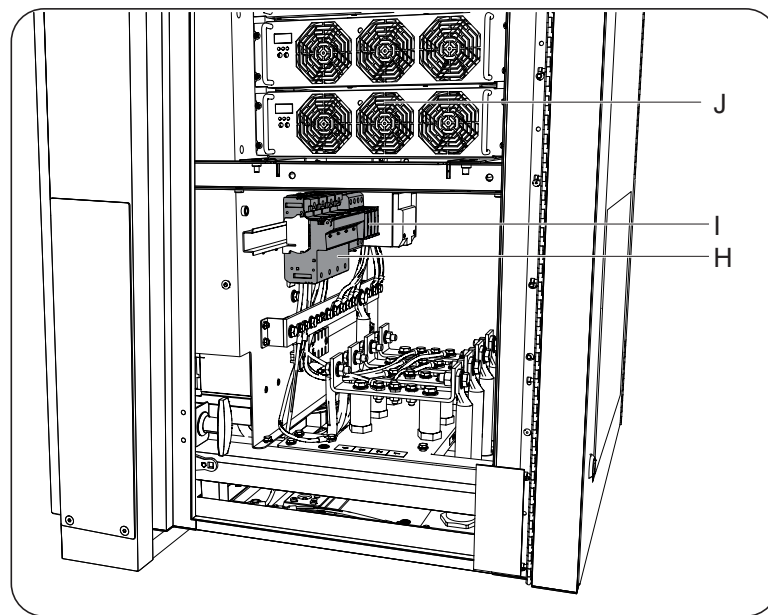

Fig. 4 Overvoltage protections

- | | |
|---|--|
| A. Main protection for DC charging circuit. 400A 50kA | E. Power module protections. 63A |
| B. Differential protection for DC charging circuit. Can be set from 30 mA to 1 A. The protections are supplied configured to 300mA. The installer should configure the protection in accordance with the applicable regulations in the country of installation. | F. Auxiliary circuit protections |
| C. Main protection for AC charging circuit. 32A 25kA | G. Differential protection for 30 mA AC charging circuit |
| D. Main protection for auxiliary circuit. 10A 25kA | H. Grid overvoltage protection |
| | I. Vehicle overvoltage protection |
| | J. Power modules |

2.5. Accessories equipped as standard

- Ethernet communication.
- Local communication with other INGETEAM stations.
- Compatible with OCPP.
- Authentication via RFID / NFC cards.
- Interface via display.

2.6. Additional options

- Payment terminal.
- Centralized communications for various chargers (Switch).
- Parked vehicle detector.
- Repowering modules for RAPID 90-120 units.
- Kit for the connection of two conductors per phase.

2.7. Acoustic contamination

The operation of this unit generates noise from the internal fans. There are two operating modes that can be selected from WEB Manager.

Interurban mode, which prioritizes the cooling of the unit.

Urban mode, which prioritizes the reduction of acoustic contamination. Ideal for residential and crowded areas.

2.8. Electrical diagram of the system

INGETEAM RAPID TRIO CCS1/CCS2/CHADEMO

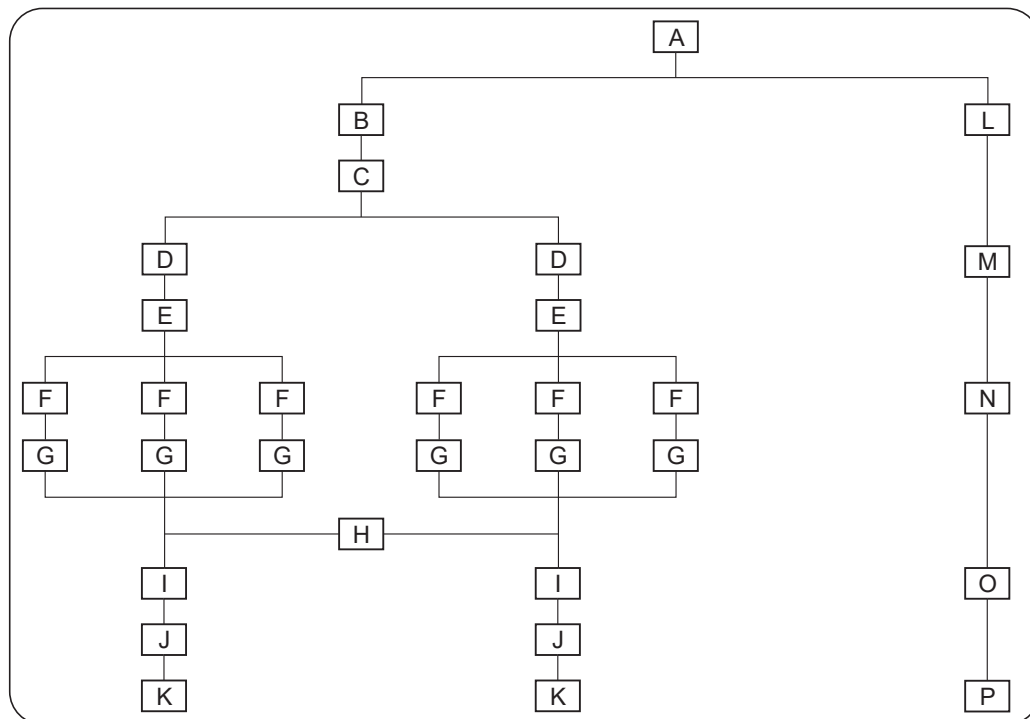

- | | |
|--|--|
| A. Supply | J. DC wattmeters |
| B. DC charging circuit breaker | K. DC connectors type CCS1/CCS2/CHADEMO (left cable always CCS type) |
| C. EMC Filter | L. AC charging circuit breaker |
| D. Protection differentials | M. Residual current device |
| E. Module power contactors | N. AC wattmeter |
| F. Module thermal magnetic protections | O. AC charging contactor |
| G. Power modules | P. AC charging connector |
| H. Shutdown contactors | |
| I. Cable contactors | |

INGETEAM RAPID DUO CCS1/CCS2/CHADEMO

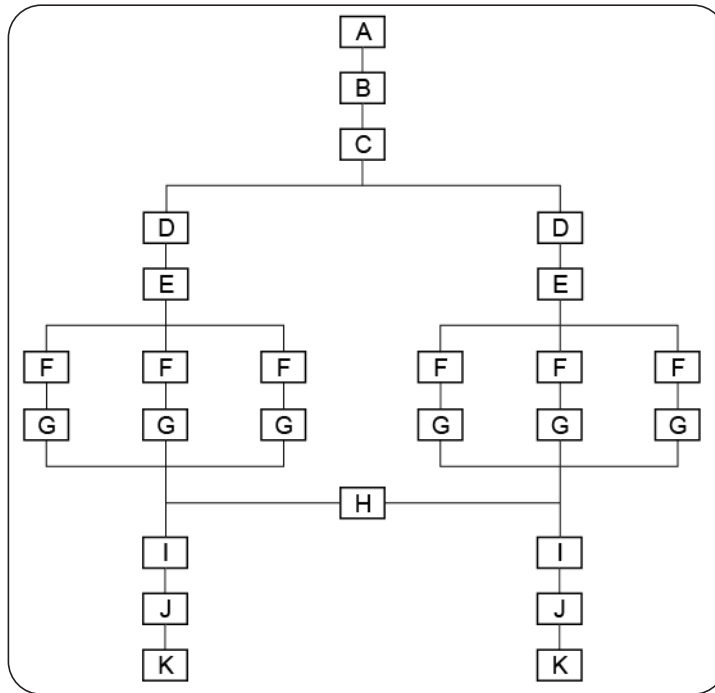

- A. Supply
- B. DC charging circuit breaker
- C. EMC filter
- D. Protection differentials
- E. Module power contactors
- F. Module thermal magnetic protections
- G. Power modules
- H. Shutdown contactors
- I. Cable contactors
- J. DC wattmeters
- K. DC connectors type CCS1/CCS2/CHADEMO (left cable always CCS type)

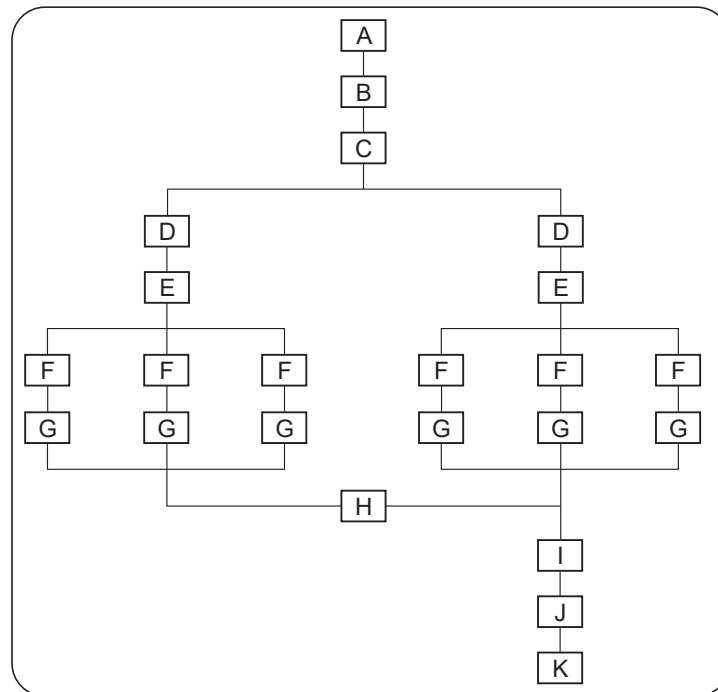
INGETEAM RAPID ONE CCS

- | | |
|--|---------------------------------|
| A. Supply | G. Power modules |
| B. DC charging circuit breaker | H. Shutdown contactors |
| C. EMC filter | I. Cable contactors |
| D. Protection differentials | J. DC wattmeters |
| E. Module power contactors | K. DC connectors type CCS1/CCS2 |
| F. Module thermal magnetic protections | |

2.9. Specification table

	INGETEAM RAPID 120	INGETEAM RAPID 180
AC inputs		
Voltage	AC 3ph.+ N + PE; 380/400/480 Vac ± 15%	
Frequency	50/60 Hz ± 5%	
Rated current	190 A + 32 A	280 A + 32 A
Rated power	120 kW + 22 kW	180 kW + 22 kW
DC output		
Voltage range	150 ~ 1000 V	
Maximum current	400A (200A+200A) @Boost 1x500 A depending on the temperature of the hose	600A (300A+300A) @Boost 1x500 A depending on the temperature of the hose
Maximum power	1 x 120 kW / 2 x 60 kW	1 x 180 kW / 2 x 90 kW
Charging connectors	CCS1/CCS2 (300 A) / CHAdeMO (125, 200 A) / 22kW AC Mode 3 Type 2 socket	
AC output (optional)		
Maximum current	32A	
Maximum power	22kW	
Charging connectors	AC Mode 3 Type 2 socket with shutters	
Regulations and safety compliance		
Standards	"IEC 61851-1 ed 3, IEC 61851-21-2 ed 1, IEC 61851-23 ed 1, IEC 61851-24 ed 1, IEC 62196-2, IEC 62196-3, IEC 61000, ISO15118, UL2202"	
Overcurrent	MCB	
Indirect contacts	"DC leakage control IEC 62955 Leakage device - 30 mA class A / class B RCD"	
Overvoltages	"Type 2 protection against permanent and transient overvoltages both on DC inputs and outputs"	
Functionalities and accessories		
Connection	Ethernet, 3G/4G modem (optional)	
Communication protocol	OCPP (standard and custom versions)	
Advertising screen	21" Full HD (optional)	
HMI	7" touchscreen, RFID (Mifare Classic 1K&4K, MifareDesFire EV1, NFC)	
Payment terminal	Bank card reader (Optional)	
Centralized communications for various chargers (Switch)	8-Connection Ethernet switch for installation	
Parked vehicle detector	Parked vehicle detector up to 2 spaces	
Repowering modules for RAPID 60E-120 units	Repowering kit to increase the power of the unit up to 180 kW	
Kit for the connection of two conductors per phase.	Kit for the connection of two connectors in each phase.	
General information		
Stand-by consumption	<250W	<330W
Retractable hose system	Included	
Hose length	6.5 m (4.5 m usable length without touching the ground)	
Energy measurement	AC (MID) and DC output measurements	
Operating temperature	-35°C ~ 55°C (high and low temperature kit option)	
Humidity	< 95%	
Weight	420 kg	465 kg
Dimensions (W x D x H)	2271 x 774 x 730 mm	
Enclosure	430 stainless steel and aluminum	
Operating height	2000 m (for higher altitudes, consult Ingeteam)	
Protection class	IP54 / IK10 (IK08 display) / C5H	
Markings	CE / MET pursuant to UL2202 (Q3 2023)	
Directives	*Low Voltage Directives: 2014/35/EU EMC Directive: 2014/30/EU RED Directive: 2014/53/EU*	

3. Receipt of the unit and storage

3.1. Reception

Keep the unit in its packaging until immediately before installation.

3.2. Unit identification

The serial number of the unit is its unique identifier. You must quote this number in any communication with Ingeteam.

The unit's serial number is marked on the specifications plate.

3.3. Transport damage

If the unit has been damaged during transport, proceed as follows:

1. Do not proceed with the installation.
2. Notify the distributor immediately within five days of receipt of the unit.

If ultimately the unit has to be returned to the manufacturer, the original packaging must be used.

3.4. Storage

CAUTION

Failure to follow the instructions in this section may lead to damage to the unit.

Ingeteam accepts no liability for damage resulting from the failure to follow these instructions.

If the unit is not installed immediately after reception, the following points should be taken into account in order to avoid damage:

- The unit must be stored in its original packaging.
- Keep the unit free of dirt (dust, shavings, grease, etc.) and away from rodents.
- Keep it away from water splashes, welding sparks, etc.
- Cover the unit with a breathable protective material in order to prevent condensation due to ambient humidity.
- Units in storage must not be subjected to weather conditions other than those indicated in section „[2.9. Specification table](#)“.
- It is very important to protect the unit from chemical products which can cause corrosion, as well as from salty atmospheres.
- Do not store the unit outdoors.

3.5. Conservation

In order to permit correct conservation of the units, they must not be removed from their original packaging until it is time to install them.

In case of prolonged storage, use dry places, avoiding, as far as possible, sharp changes in temperature.

Deterioration of the packaging (tears, holes, etc.) prevents the units from being kept in optimum conditions before installation. Ingeteam accepts no liability in the case of failing to observe this condition.

4. Transporting and handling the unit

You must protect the unit, during transport, from mechanical knocks, vibrations and any other product or situation which may damage it or alter its behavior.

Failure to observe these instructions may lead to loss of warranty on the product.

4.1. Unpacking

Correct handling of the units is vitally important in order to:

- Prevent damage to the packaging which enables them to be kept in optimum condition from shipping until they are installed.
- Avoid knocks and/or falls which may harm the mechanical features of the units, e.g. cause incorrect closure of doors, loss of IP rating, etc.
- Avoid, as far as possible, vibrations which may cause subsequent malfunction.

If you observe any anomaly, please contact Ingeteam immediately.

Separating the packaging

You can deliver all the packaging to an authorized non-hazardous waste management company.

In any event, each part of the packaging may be recycled as follows:

- Plastic (polystyrene, bag and bubble wrap): the appropriate container.
- Cardboard: the appropriate container.

4.2. Lifting

The RAPID family of charging stations have been designed to be handled from the top.

Carry out the following steps:

1. Firstly, fit the lifting parts indicated in the image below. To do so, you will need the following screws:
 - 8 x DIN9021 M8 nylon washer
 - 8 x Contact M (NFE25511) M8 stainless steel washer A2-70
 - 8 x DIN933 M8x20 mm galvanized screw, quality 8.8

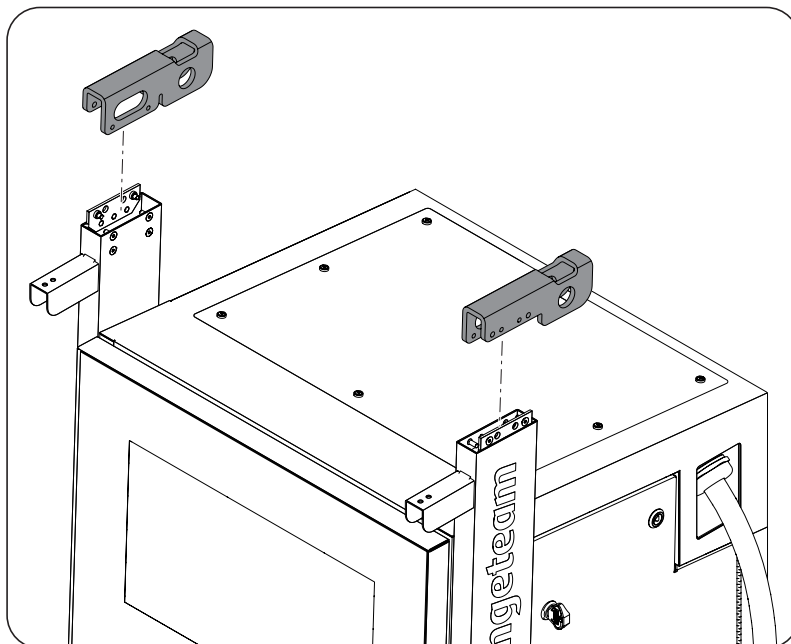

Step 1: fit lifting parts

2. The lifting parts are secured and tightened to a torque of 20 Nm.

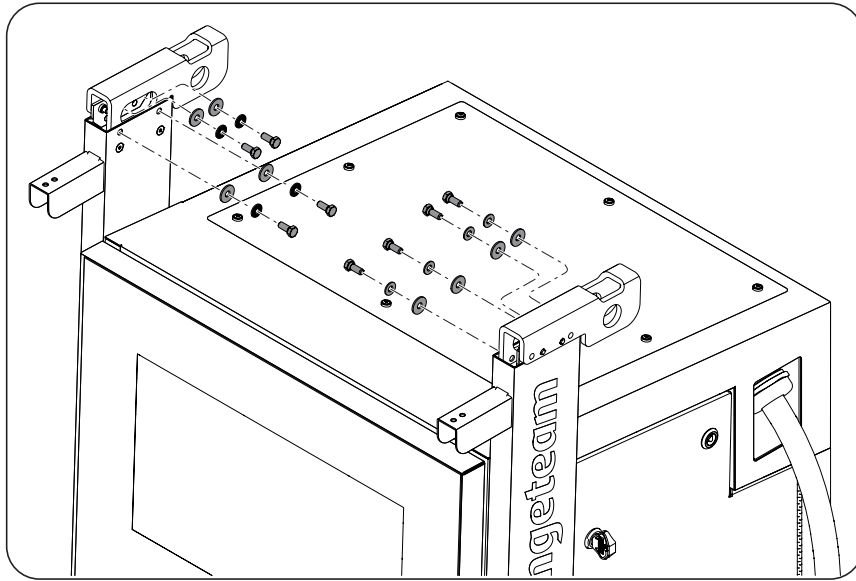

3. The lifting operation is then carried out. There are two possibilities:
 - Using hooks attached to the lifting point.

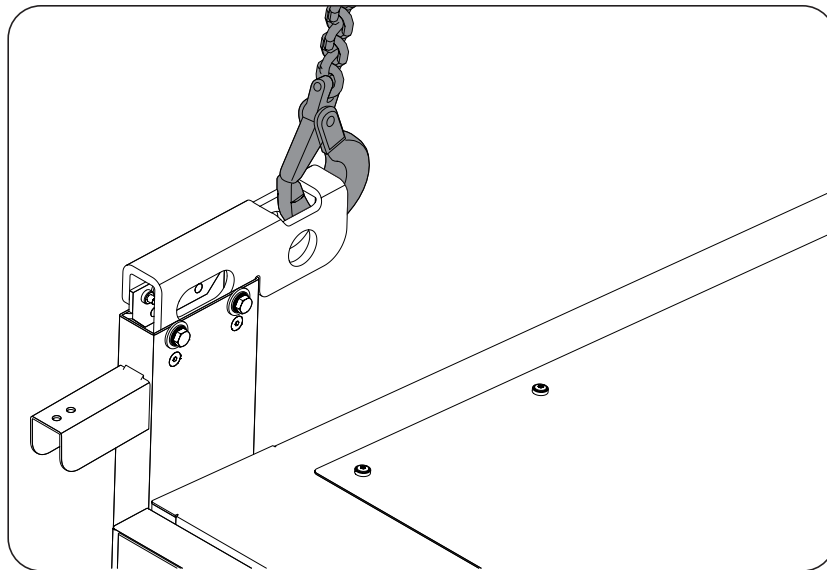

- Using shackles attached to the lifting point.

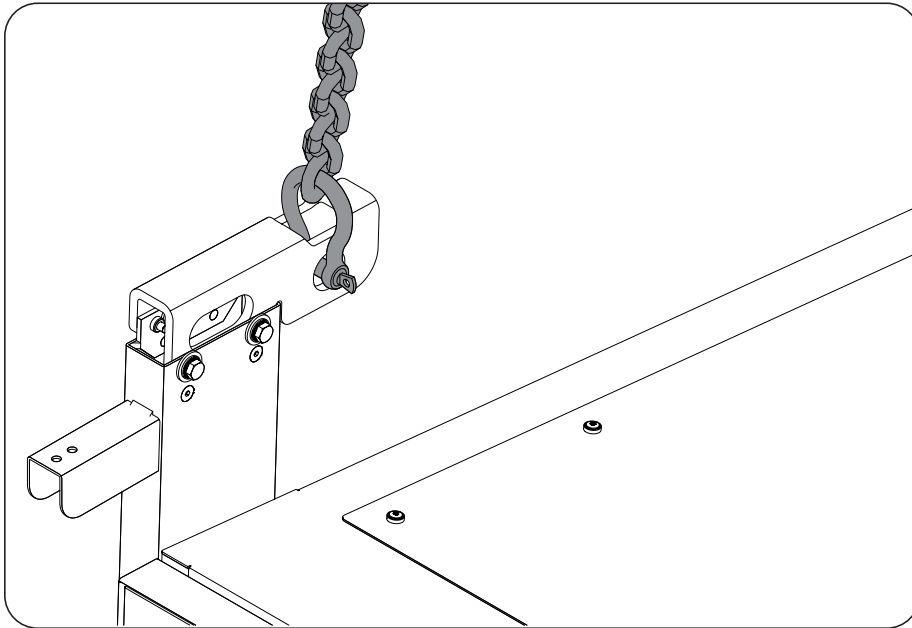

⚠ WARNING

Take care when loading and transporting the unit.

Before subjecting cables, ropes, slings, etc. to traction force, you must inspect them, as well as the fastening and attachment points.

Never exceed the maximum payload of the lifting elements.

Before lifting the unit, lift it slightly to check its stability. In the event of tilted loads, descend and carry out a sling operation to ensure a stable load.

4.3. Fitting the ring

1. Finally, fit the upper part of the ring. To do so, fit the 8 fastening bolts.
2. Connect the power supply for the lights and fit the ring.

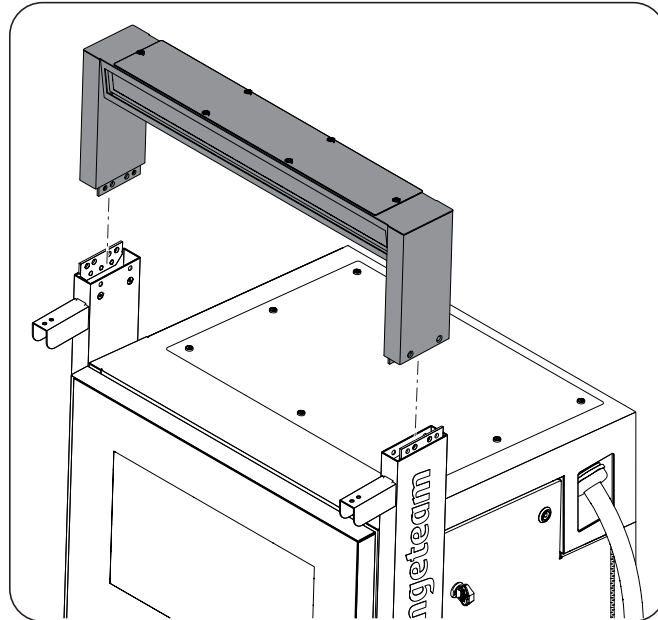

3. Fit the ring using the screws provided. Apply a torque of 6.7 Nm.

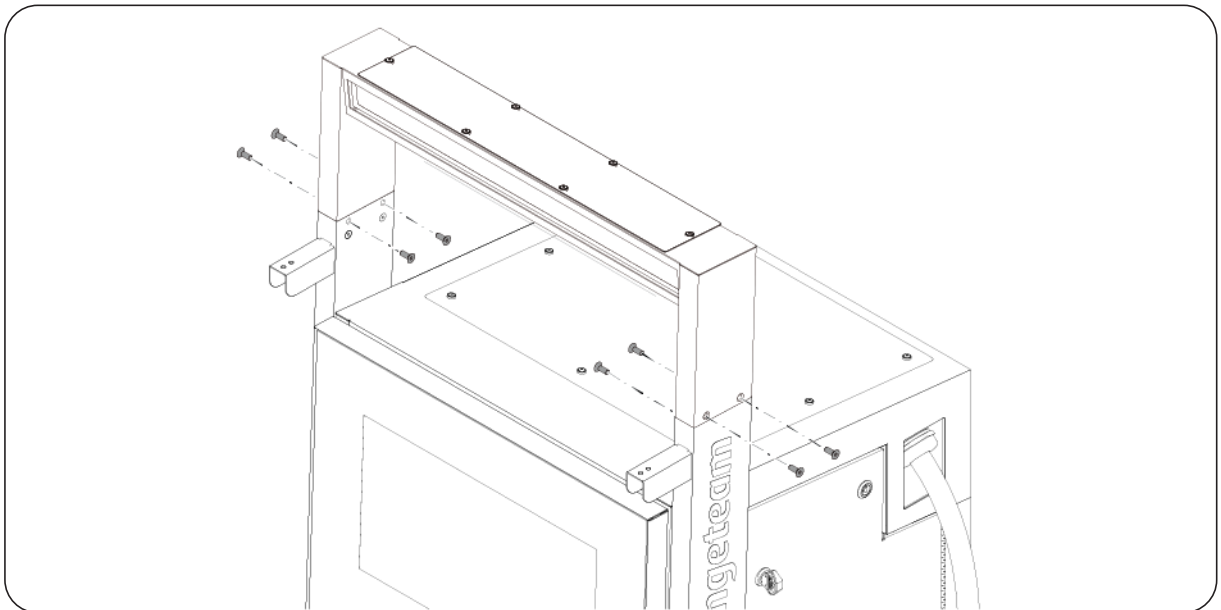

5. Preparation for installing the unit

When deciding the location of the unit and planning your installation, you must follow a set of guidelines based on the specifications of the unit. These guidelines are summarized in this chapter.

5.1. Environment

- Place the units in a place that is accessible for installation and maintenance work and which allows operating through the TFT display.
- The air vents and part of the power module can reach high temperatures. Do not place any material nearby which is sensitive to high air temperatures.
- Avoid corrosive environments that may affect its proper operation. Do not install the unit in areas classified as ATEX.
- Never place any object on top of the unit.
- It is recommended to place the units under a cover that protects them from direct radiation, placing the front part facing north in the Northern Hemisphere and facing south in the Southern Hemisphere.
- Keep the following minimum distances free of obstacles.

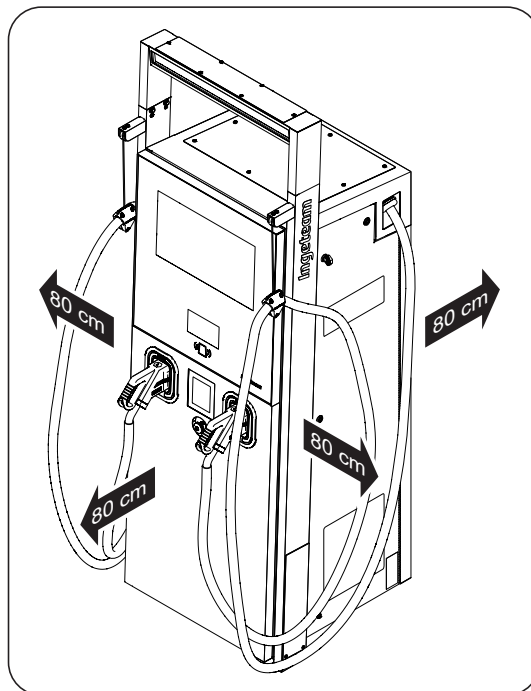

Minimum clearance distances

5.2. Environmental conditions

Environmental conditions must be taken into account when choosing the location of the unit.

Environmental conditions	
Minimum temperature	-35°C ⁽¹⁾
Minimum surrounding air temperature	-35°C ⁽¹⁾
Maximum operating temperature	60°C ⁽²⁾
Maximum relative humidity without condensation	95%
Altitude	2000 m ⁽³⁾

⁽¹⁾ Ask Ingeteam. Low temperature kit.

⁽²⁾ The operation of the unit at temperatures greater than 40°C should only occur occasionally and not permanently. The unit can enter reduced performance mode (derating).

Ingeteam is not responsible for the consequences to the unit resulting from operating it at temperatures higher than 40°C.

⁽³⁾ At altitudes higher than 2.000m, please contact Ingeteam.

It should be borne in mind that moderate condensation may occasionally occur as a consequence of temperature variations. For this reason, apart from the unit's own protection, it is necessary to monitor these units once they have been started up on sites where the conditions described above are not expected to be present.

In the event of condensation, never apply voltage to the unit. To remove condensation apply a flow of hot air at a maximum temperature of 60°C.

INFO

Ingeteam does not guarantee the proper operation of the equipment if the operation conditions for which it has been designed are not fulfilled.

5.3. Type of grid

These units must be connected to a three-phase grid with a star formation with grounded neutral. Therefore, admissible grounding systems are TT, TN-S and TN-C-S.

They cannot be connected to IT, TN-C grids or delta grids with one of their lines grounded.

The connections from the three-phase grid (L1, L2, L3 and N) and its ground (PE) must go to the unit.

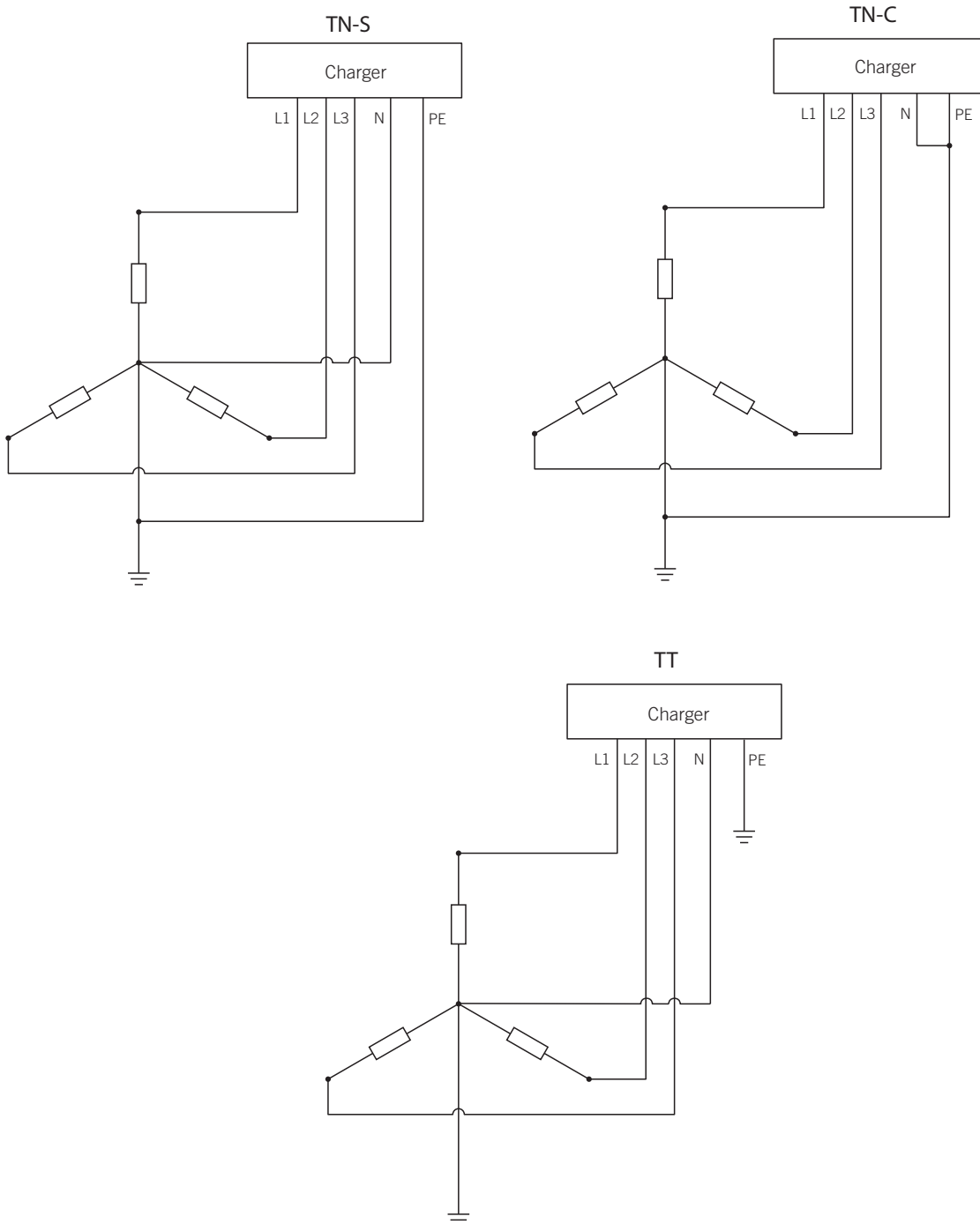

5.4. External disconnection device

The AC supply must be shut off for equipment inspection work. To do this, the installer must fit an external disconnection device.

The switching component must be dimensioned for the DC input voltage and current of the charging terminal (see section [“2.9 Specification table”](#)).

It can also include the possibility of remote tripping (via minimum coil) that allows it to be opened in case the charging terminal door is opened accidentally.

6. Installing the unit

Before installing the unit, the packaging must be removed, taking special care not to damage the housing (see section „4.1. Unpacking“).

Check that there is no condensation inside the packaging. If there are signs of condensation, the unit must not be installed until you are sure it is completely dry.

⚠ CAUTION

All installation operations must comply with current regulations.

All operations involving moving heavy weights must be carried out using the required mechanical means (crane, hoist, etc.).

6.1. General requirements for installation

The environment of the unit must be appropriate, leaving minimum distances that allow the doors to open for maintenance work (80 cm).

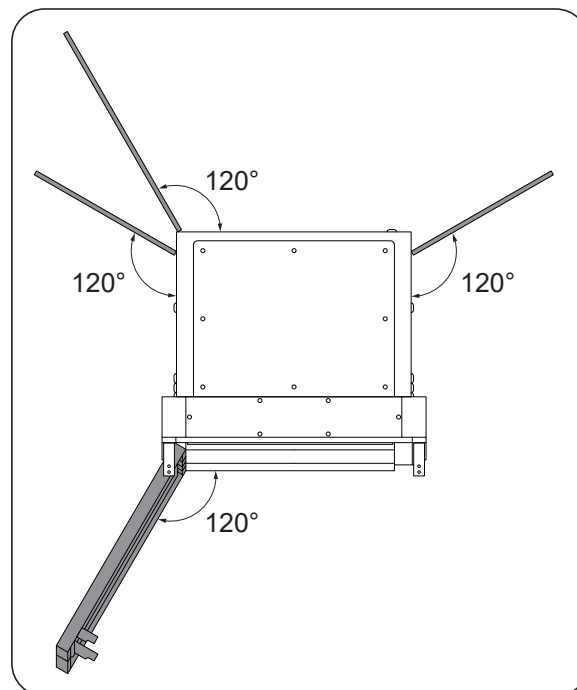

The images shows the opening of the doors. A space of 80 cm must be left on all four sides of the charger, defined by the opening of the doors plus a passing distance.

The opening angle of the doors is up to 120°. However a smaller angle is permitted, of at least 90° to permit maintenance work.

The connection cables must be appropriately sized for the maximum current and service voltage.

Special care must be taken to ensure that there are no external elements near the air inlets and outlets that obstruct proper cooling of the unit.

6.2. Fastening the unit

The fixing points are designed for the use of threaded rods or M12 screws. If using a threaded rod, its length above the ground must be 25 to 35 mm.

Other similar anchoring systems can be used.

The separation of the fastening system selected must be adjusted to the measurements shown below in a detail of the lower part of the charger.

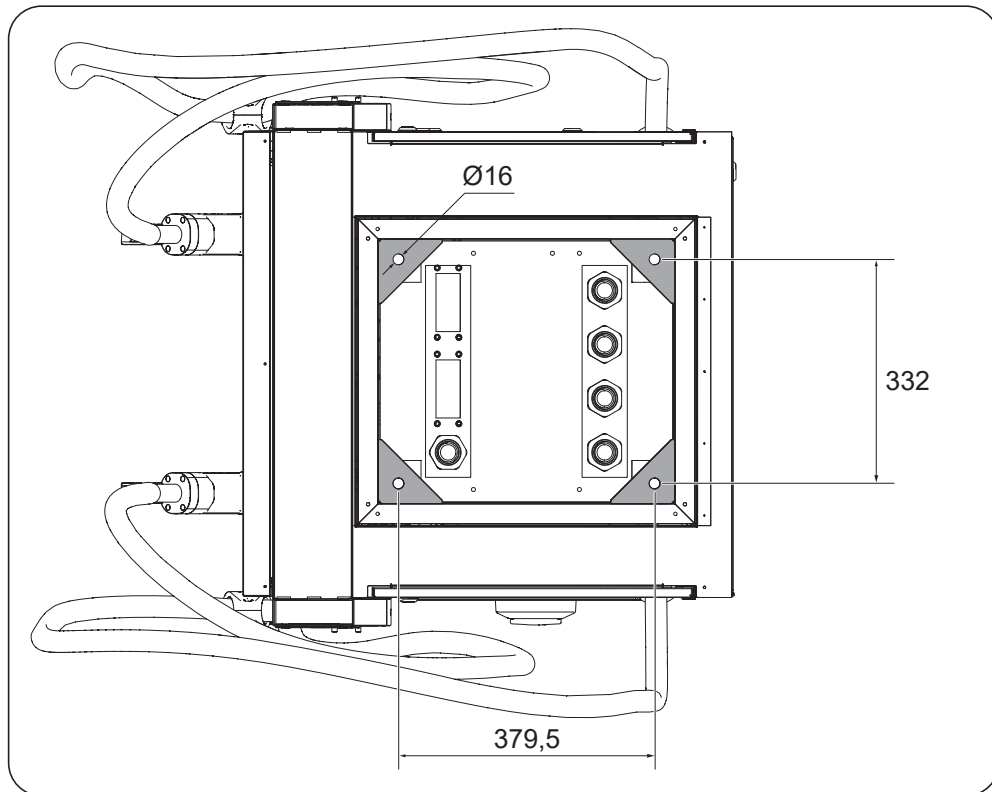

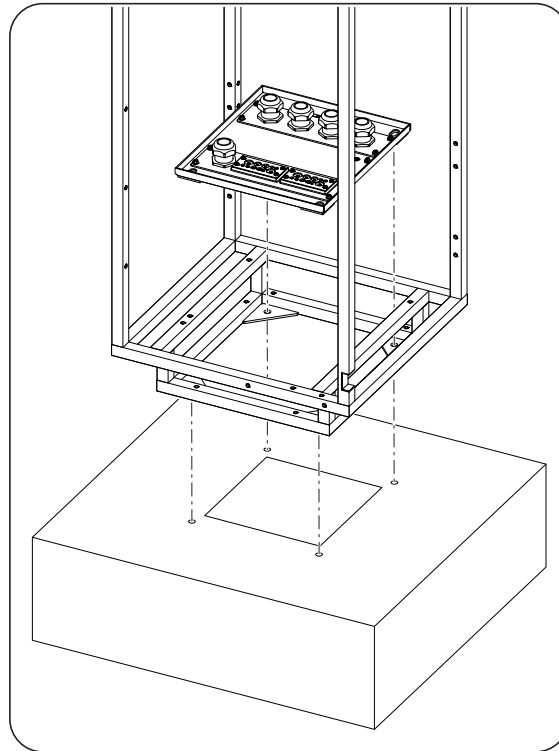

You must follow the following stipulations when choosing the place where the unit is to be bolted in:

- Minimum distance from the center of the bore to the outer edge of the concrete pad: 75mm.
- The distance from the center of the bore to the inner edges must be 39 mm.
- If you use a different anchoring system, check that the solution provided complies with the conditions initially defined in this document.
- Minimum thickness of the concrete pad: 300mm.
- The dimensions of the inspection chamber of the pad are shown in the following figure.

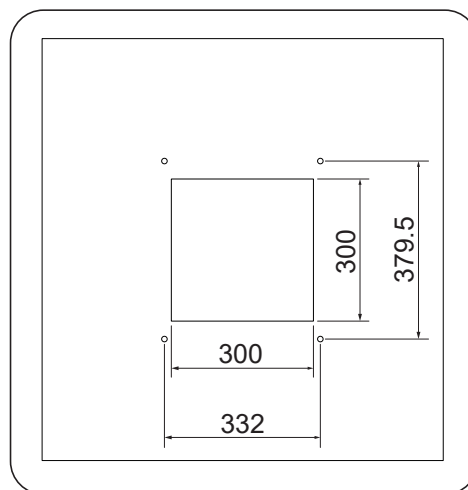

- Minimum depth of the inspection chamber of the pad of 200 mm. This allows a standard cable of 240 mm² with a turning radius of 135 mm to turn (e.g. XZHELLENT XXI 1000 V RZ1-K (AS) 0.6-1 kV).

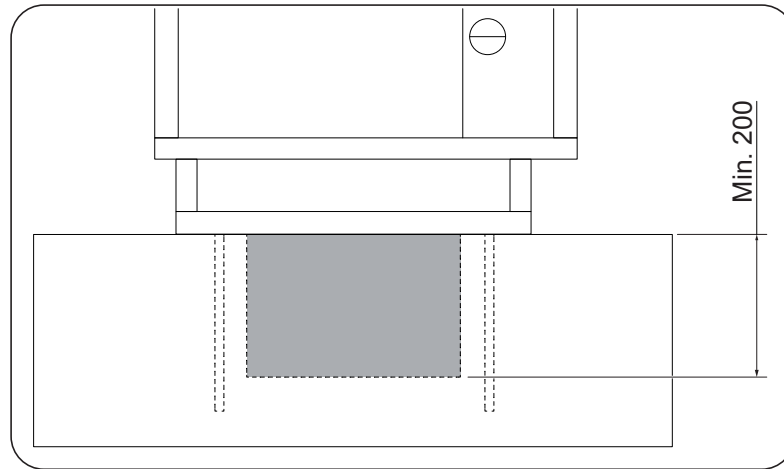

- If the radius of curvature of the selected cable is greater than the radius of curvature of 135 mm, the depth of the inspection chamber must be greater.
- The minimum depth of the anchoring system must be inserted a minimum of 45 mm into the concrete. This anchoring system must comply with the following parameters:
 - Minimum tensile strength: 7.7kN. Security coefficient 1.5.
 - Minimum shear strength: 9.3kN. Security coefficient 1.25.

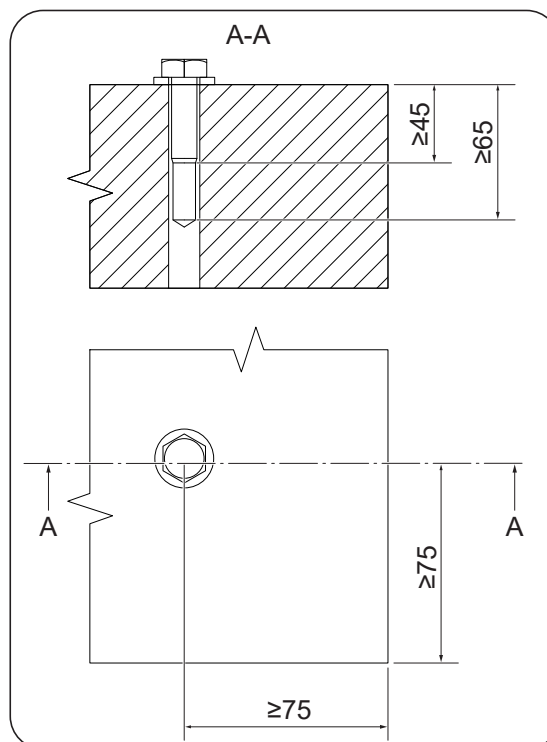

A set of gages is included that allows slight unevenness on the pad. The gages must be fitted depending on the unevenness to be corrected. If there is no unevenness, there is no need to fit the gages.

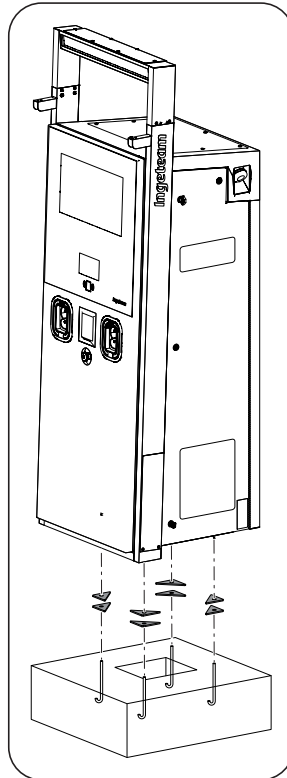

It is recommended that the front and rear doors of the unit remain closed when fitting the unit in position. The side doors are used to help with the fitting.

The interface plate that houses the cable glands can also be removed in order to facilitate the passage of power cables. It must then be re-installed in order to ensure the unit's IP.

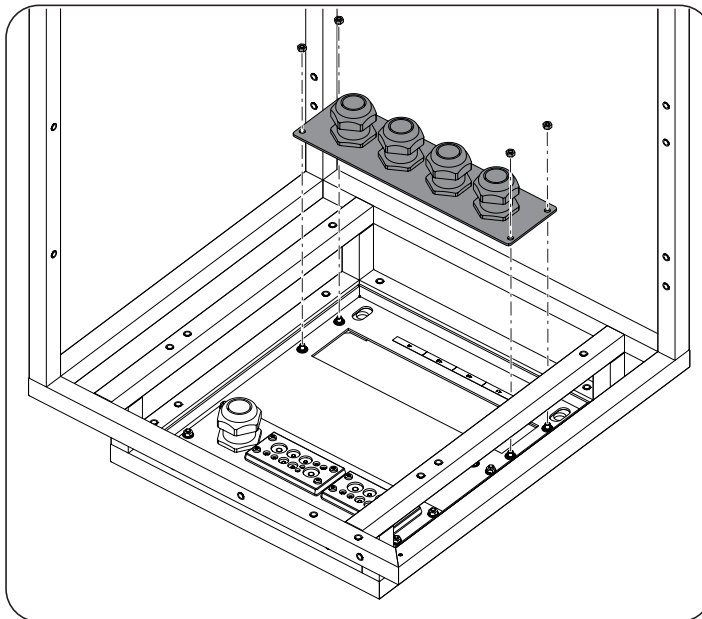

7. Connection of accessories

This chapter explains the process for wiring the standard and optional accessories to the unit.

Read carefully before starting the connection process.

7.1. Safety instructions for connecting accessories

DANGER

There must not be any active charge in the charger.

The charger must not be connected to any vehicle.

Make sure there is no voltage present on the unit before starting the connection.

Lock and tagout any possible external feedback from the unit.

Mark the external power system with a Personnel Working Warning.

Open the unit using the personal protective equipment defined in this manual.

Confirm the absence of voltage in the connection to the unit.

Confirm the absence of voltage when dismantling any protection against direct contact.

CAUTION

Ingeteam accepts no liability for any damages caused by an incorrect connection.

7.2. VISA kit

Download the manual corresponding to each payment terminal from the INGETEAM Training platform.

<https://www.ingeteamevctraining.com/>

7.3. Connection kit for two cables

This Kit enables the connection of two cables to each exterior power phase of the charger.

CAUTION

To install the kit it is necessary to access the unit, following the safety instructions given in this manual. The unit must not be powered.

1. Remove the polycarbonate sheet covering the connection busbars. Set the screws to one side for use at a later stage.

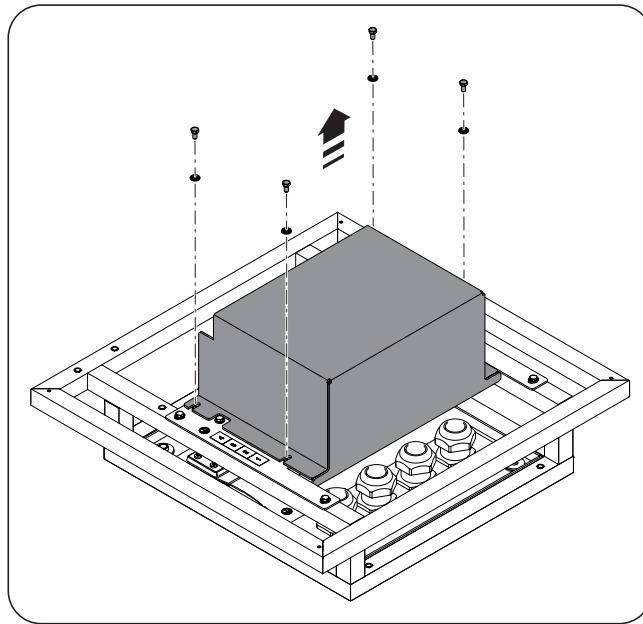

2. Remove the interface plate. And set the screws to one side for use again at a later stage.

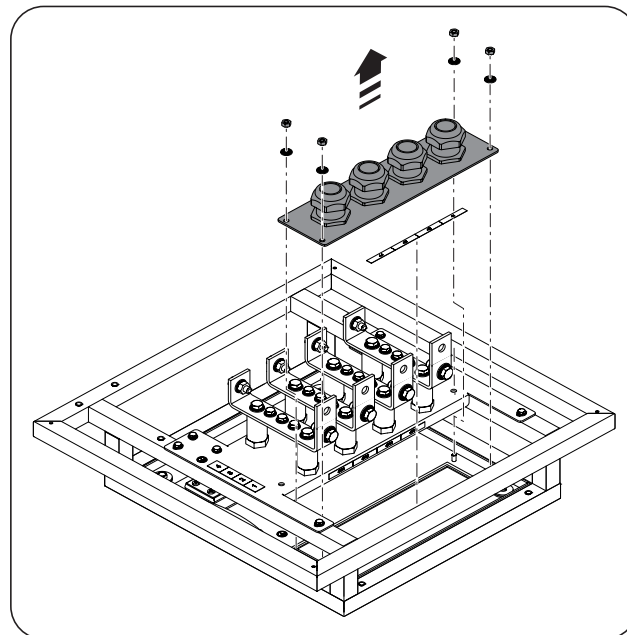

3. The busbars must be mounted as shown in the image. Apply a torque of 43 Nm.

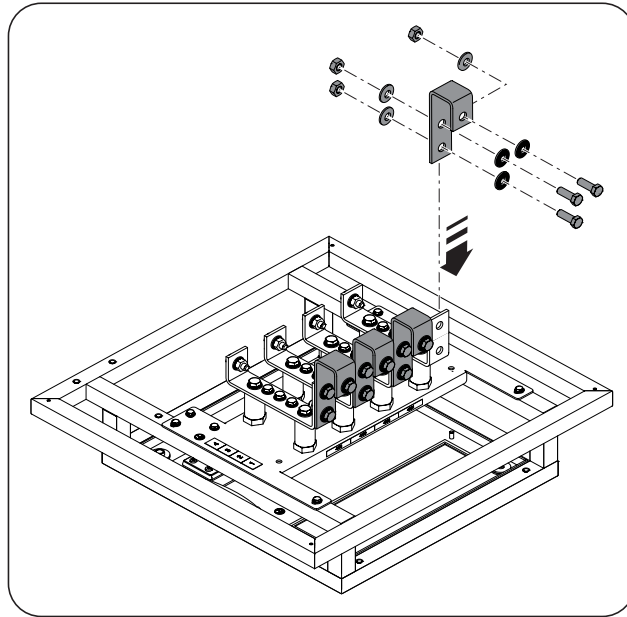

4. Mount the new interface plate with the screws set aside earlier. The tightening torque for these screws is 3.5 Nm.

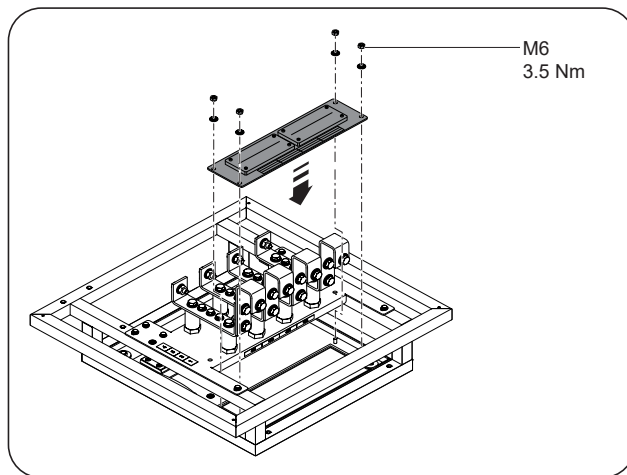

5. On completion of the installation of the charger in its final position, connect the cables at the designated points. The tightening torque for the cable connection screws and the busbar fastening screws is 60 Nm.

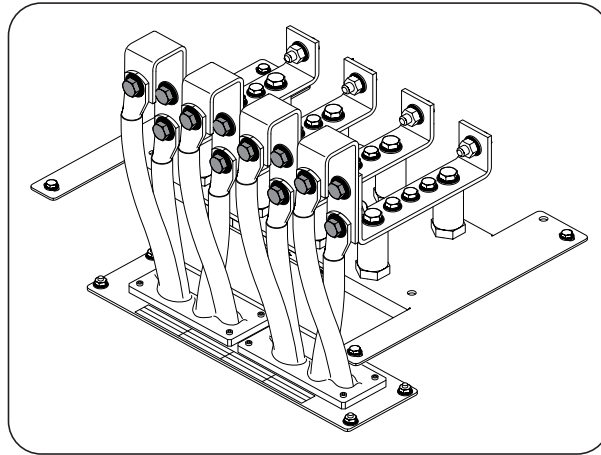

6. Fill the spaces below the new interface plate for the passage of power cables with polyurethane foam to ensure that the unit is sealed.
7. Fit the new polycarbonate sheet to cover the connection busbars.

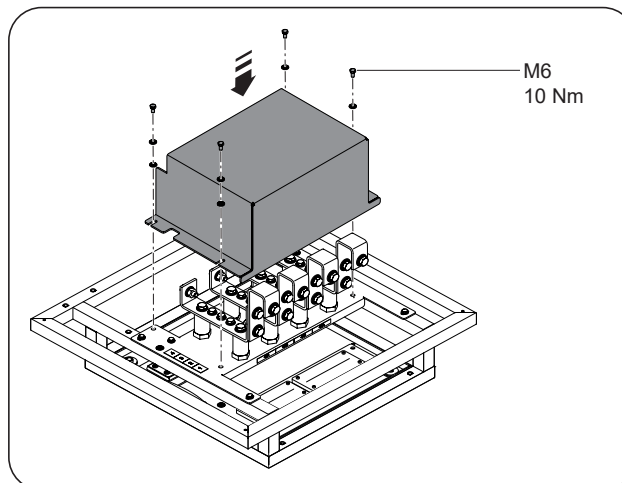

7.4. External communication interconnection Kit

This kit permits the connection of an installation of up to 8 RAPID 180 using a switch. It contains an 8-port switch which permits the interconnection of up to 8 chargers in the installation.

7.4.1. Mechanical installation

The Ethernet switch must be installed on the lower DIN rail of the front mounting plate in the position shown in the figure.

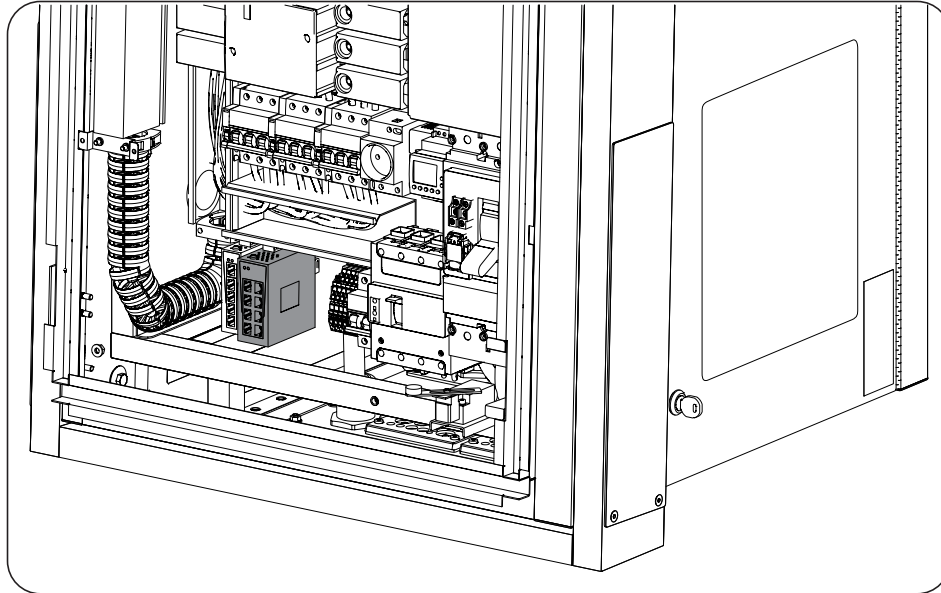

7.4.2. Electrical connection

Switch power supply:

1. The Ethernet switch kit includes two blue cables which must be connected to the switch connector in the + and – positions, in accordance with the printing on the cables.
2. Next, the cables must be routed through the ducts to the –XD2 distribution terminal block. Connect the other end of the cables in accordance with the printing on the cables to points 9+:-3 and 2-:-6.

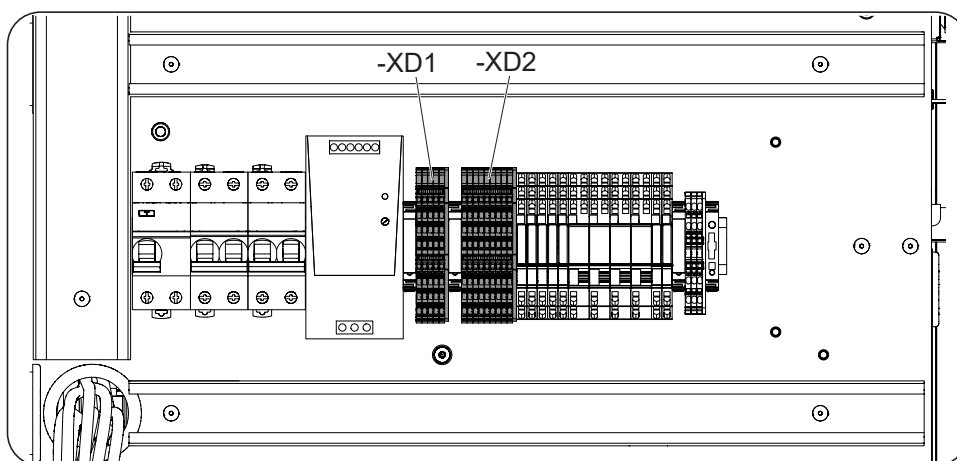

Terminal communications:

1. The Ethernet switch kit includes an Ethernet cable.

- The Ethernet cable must be connected to port number 1 of the switch, routing it through the ducts to the control card which is in the port and connected to the J13 port of the electronic card.

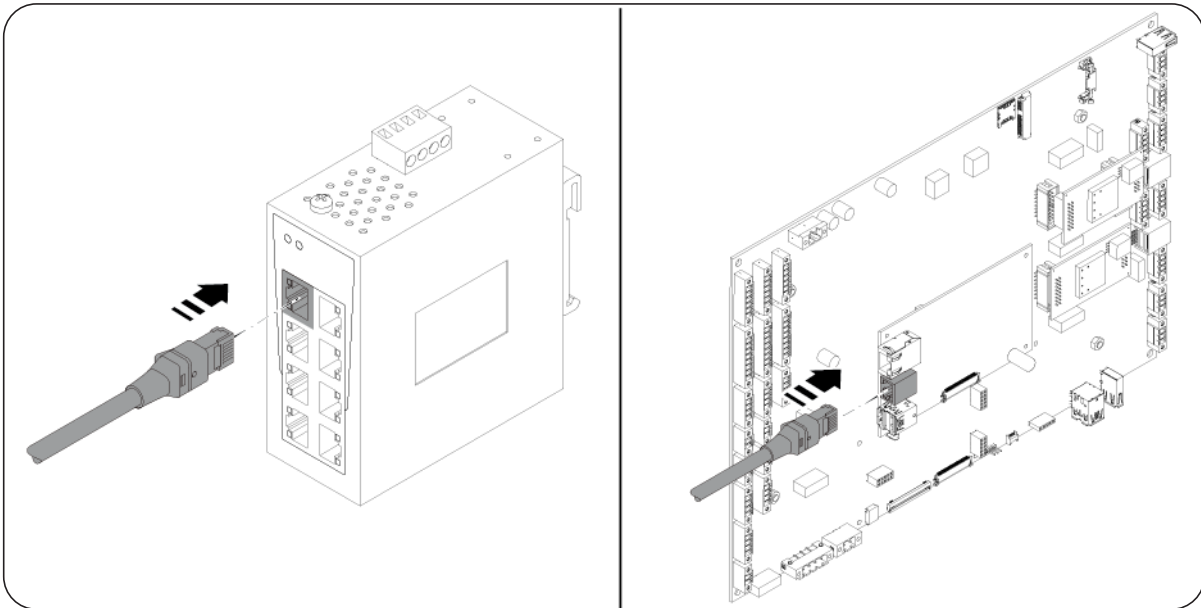

- The remaining Ethernet cables from the other chargers of the installation should be inserted through the underground conduits and should go through the cable input system defined to this effect. To make the installation easier, the wall bushings may be released. On completion of the work, the bushings must be re-installed to ensure the unit is sealed.

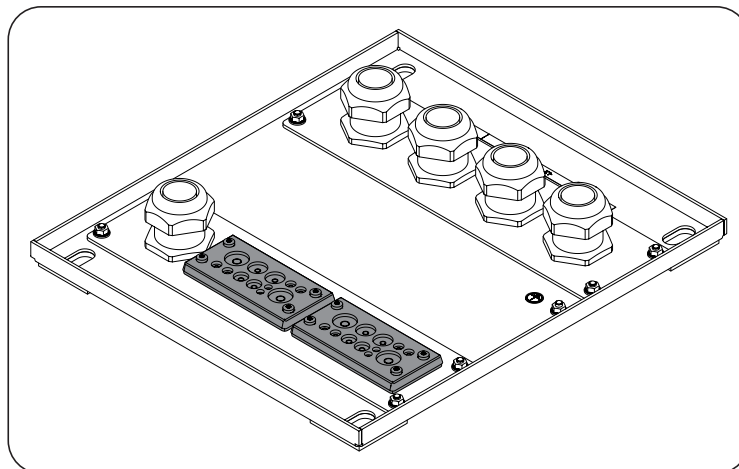

7.5. Repowering kit

This kit contains a 30 kW power module, the screws required to mount the module and a new specifications label.

CAUTION

To install the kit it is necessary to access the unit, following the safety instructions given in this manual. The unit must not be powered.

To install the module, follow the steps below.

1. Remove the deflector. Release the plate shown depending on the module to be mounted.

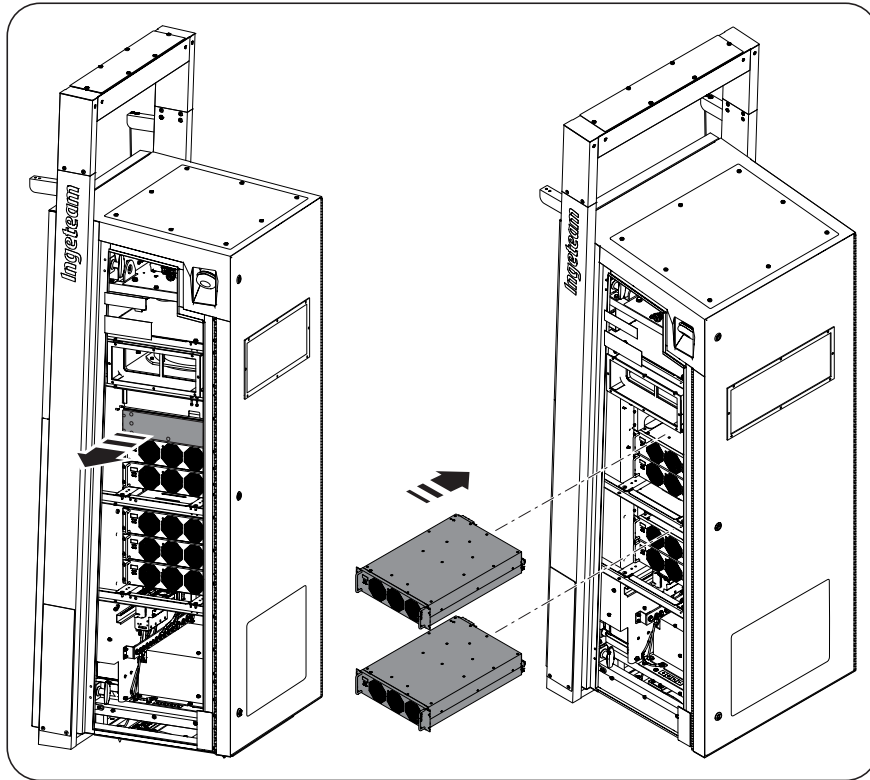

2. Insert the module in its position.

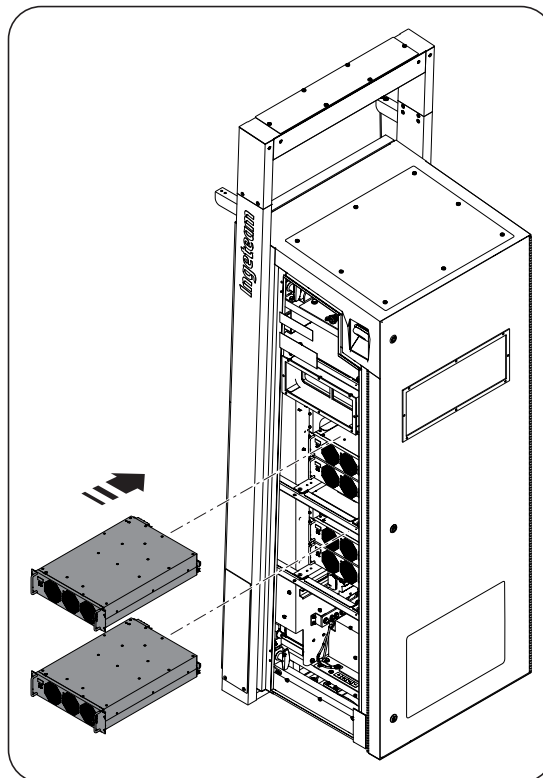

3. Bolt the module to ensure it is securely fastened with the correct screws.

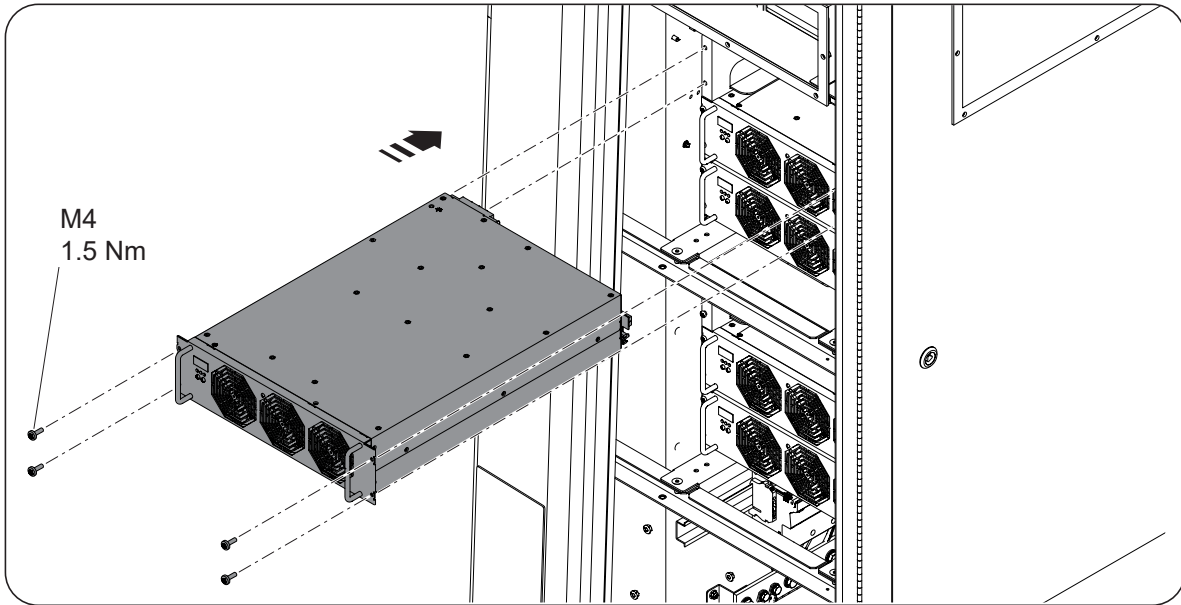

4. Connect the AC and DC wiring to the rear of the module.

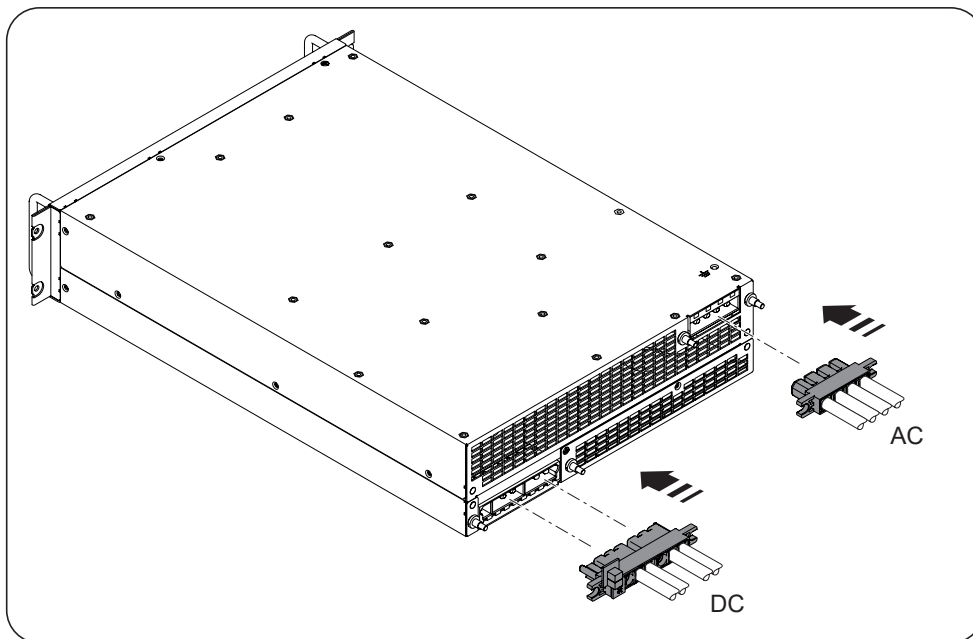

5. Ensure that the communication hose is connected to the module connector.

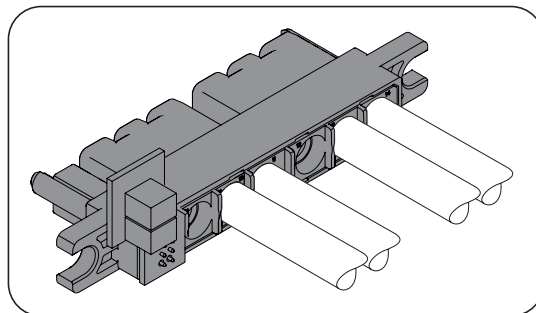

6. Replace the specifications label of the unit with the new labels provided in the kit.
7. Raise the protection of each module located on the front mounting plate.
8. Follow the instructions for start up described in this manual.

7.6. Electric vehicle detector

CAUTION

To install the kit it is necessary to access the unit, following the safety instructions given in this manual. The unit must not be powered.

1. Mount the electric vehicle detector in the position shown in the figure.

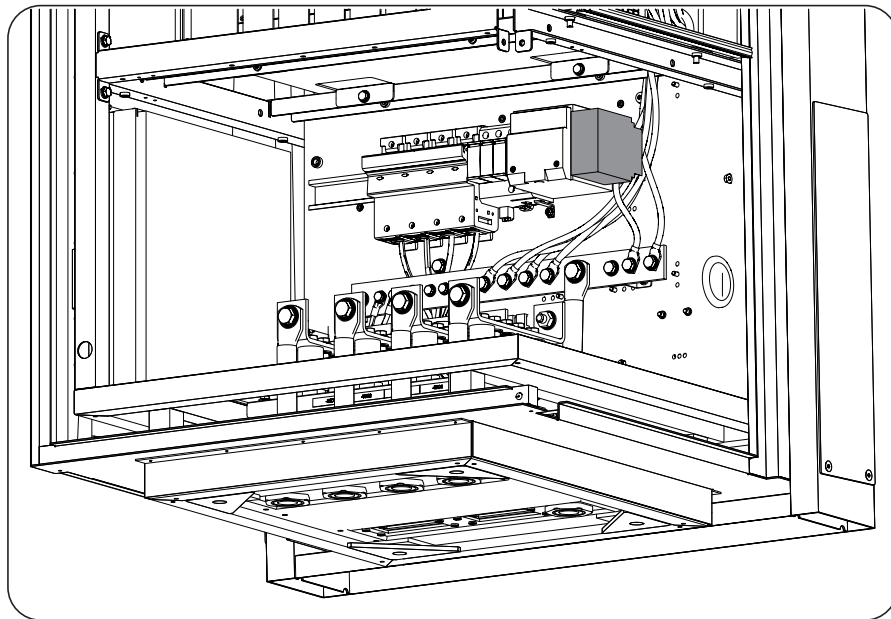

2. Connect the detector to the wiring kit included in this kit. The start and end points are marked on each cable. This helps to connect each one. Route all the cables through the ducts installed for this purpose.
3. The identifier of the detector is –BG7. It is marked in this way on the cables and the following cable connection points are as follows.
 - a. The distribution terminal blocks are –XD1 and –XD2.

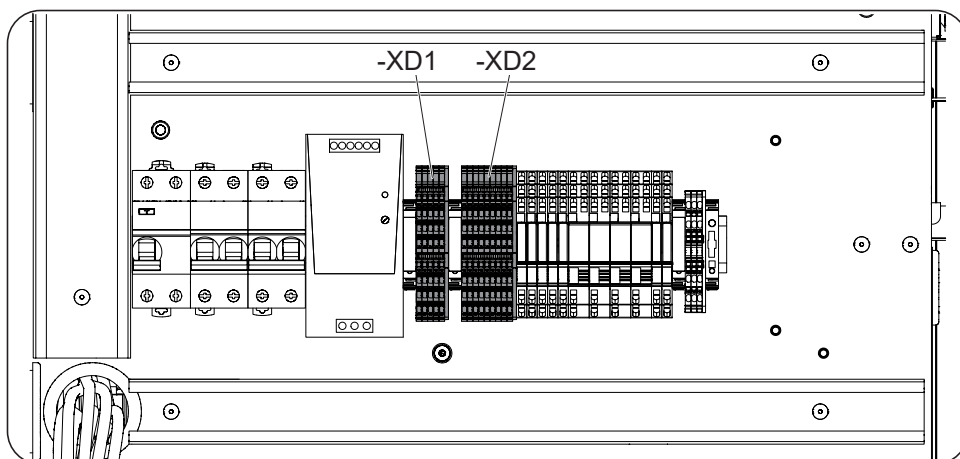

b. The electronic card is identified by the name –KZ1. The J26 connector is in the zone marked in the figure.

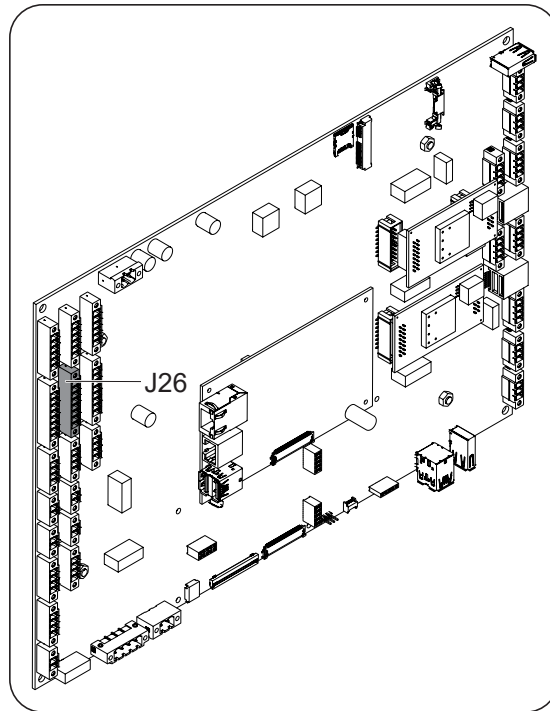

c. The detector must be tared with the standard parameters which are defined in the figure below. If the special features of the installation require a different taring, please refer to the appliance user manual.

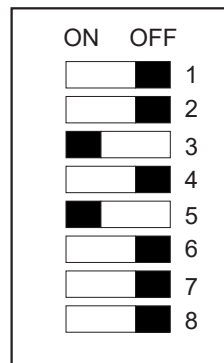

Configuration of detector

7.7. 4G communications kit

⚠ CAUTION

To install the kit it is necessary to access the unit, following the safety instructions given in this manual. The unit must not be powered.

It is possible to install a 4G communications card as the installation of the 4G card is very simple.

1. Firstly, insert the 4G card into the J31 port on the electronic card –KZ1 (ABX0011).

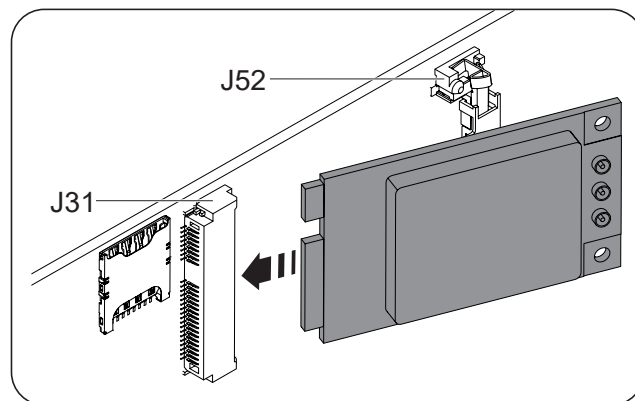
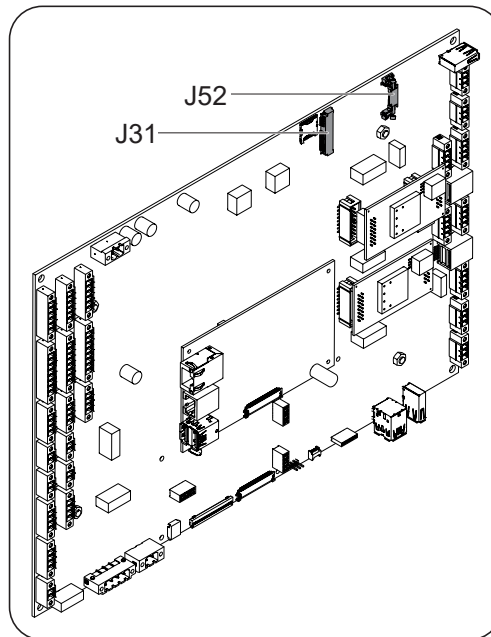

- Then lower the other end of the card until it is locked in port J52.

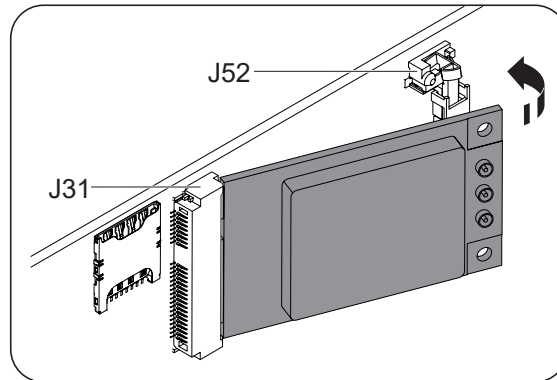

- Subsequently, the 4G antenna cable must be connected to the card. The connection point is identified with the text “MAIN” or “M”.

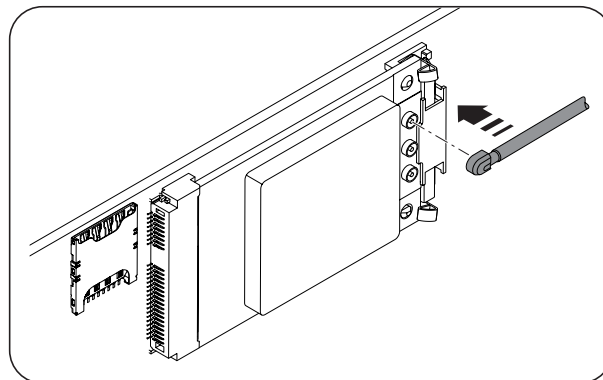

- Finally, insert the MicroSim card into the housing defined for this purpose.

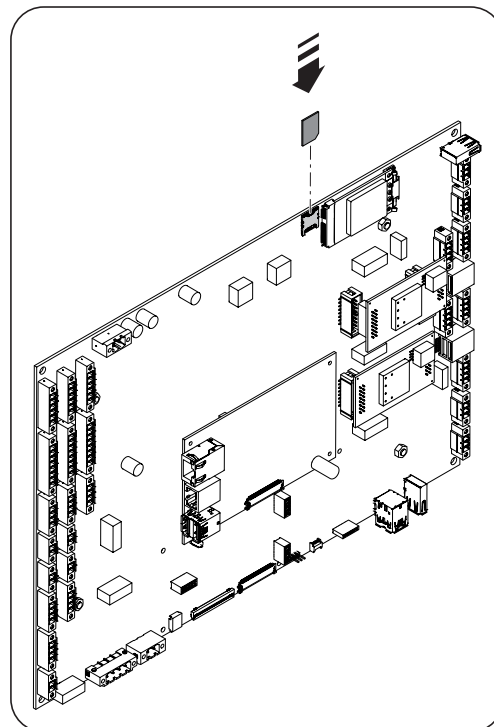

7.8. Leveling gage kit

There is an optional kit with gages that allows slight unevenness to be compensated on the slab. These are parts that must be fitted before placing the unit in its final position.

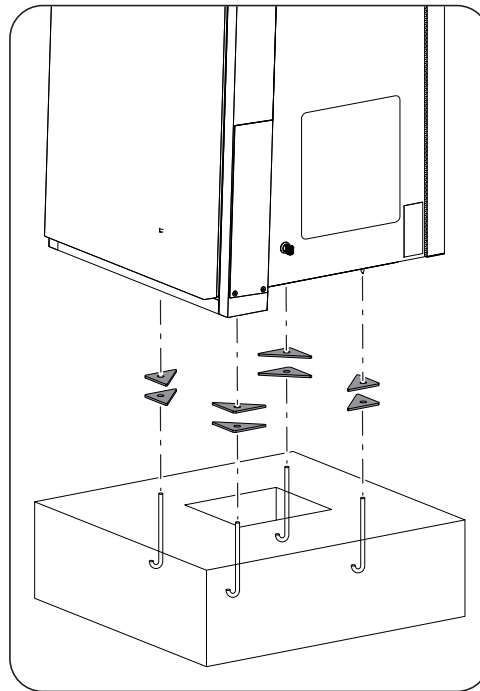

8. Charger power supply connection

This chapter explains the requirements and process for connecting the power supply cabling to the unit. The circuits for DC and AC (if available) charging and the auxiliary services power supply are derived internally from this connection. Read carefully before starting the connection process.

INFO

Consult section „*Important safety instructions*“ and the following instructions before working on the unit.

8.1. Safety instructions for the AC connection

DANGER

Make sure there is no voltage present on the unit before starting the AC connection.

Do not switch on the power to the unit until you have successfully made the rest of the connections and it is closed.

Use the Personal Protective Equipment specified in section „*Personal Protective Equipment (PPE)*“.

During the connection, ensure the correct connection of the cables to the corresponding busbars.

It is essential to correctly replace the IP2X protections once the AC connections have been made.

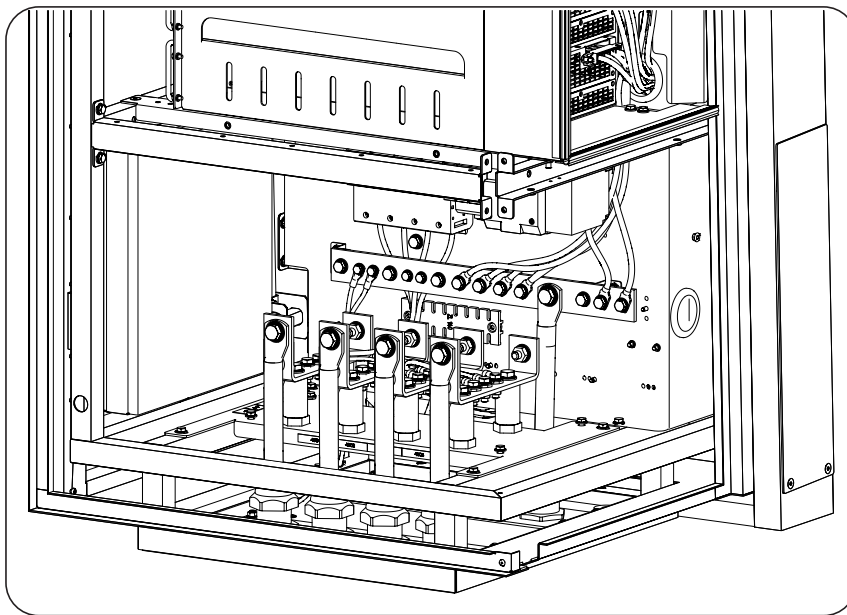

Fig. 5 Image of the IP2X protection of the connection

8.2. Cabling requirements

To guarantee the safety of persons, for the unit to function correctly and comply with the applicable standards, the unit must be connected to the ground of the installation.

The AC connection must comply with section 8.3. The installation must use single-pole cables with a copper or aluminum conductor.

The connection of two cables per phase with a cross section of up to 240 mm² is permitted, and a cable with the same cross section for the neutral and the protection (ground).

CAUTION

If using aluminum cables, the installer must provide the necessary means to prevent galvanic coupling (bipolar terminals, bimetallic interfaces, etc.).

The dimensioning of the ground wiring will be the responsibility of the installer and must meet applicable regulatory requirements in the installation.

The connection admits a cable section of between 95 mm² and 240 mm². The range of admissible diameters for the input cables is between 18 and 32mm. The cables must finish in an M12 spade terminal. The cable should be passed through the cable gland before mounting the terminal.

8.3. Connection process

1. Insert the wiring through the cable inlets provided in the lower part of the charger.

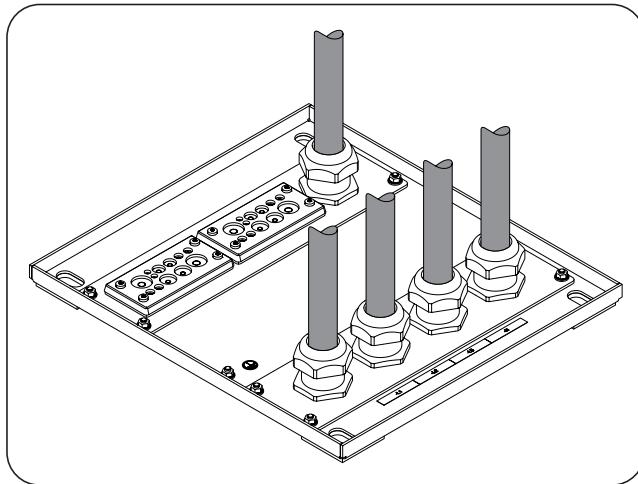

2. Connect the three phases, neutral and ground to the busbars, respecting the polarities. The busbars are marked with various classifications, in line with the systems of different countries. The classification system of the country of installation must be followed.

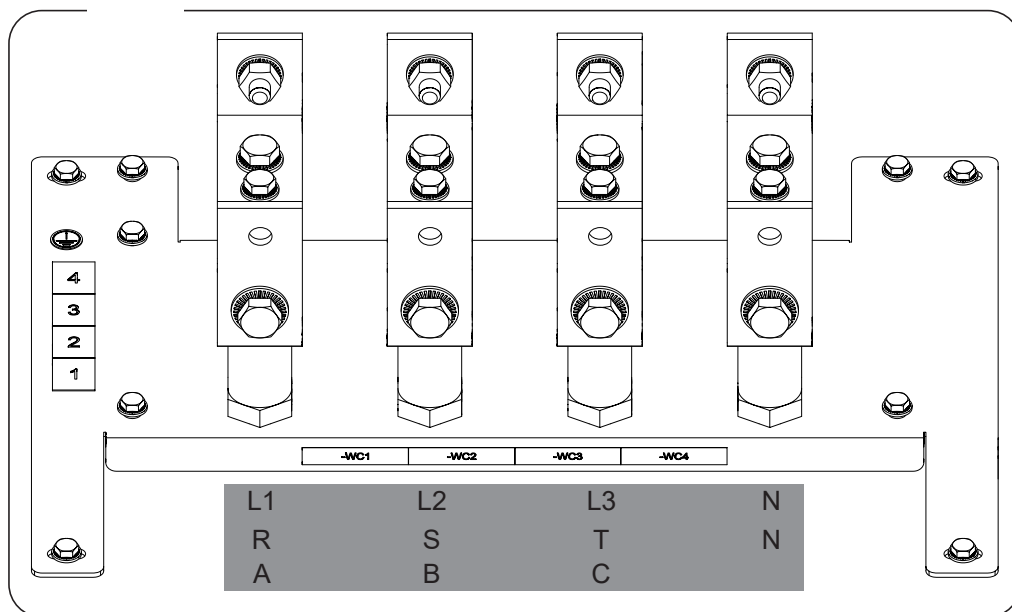

The grounding busbar is identified in the image below.

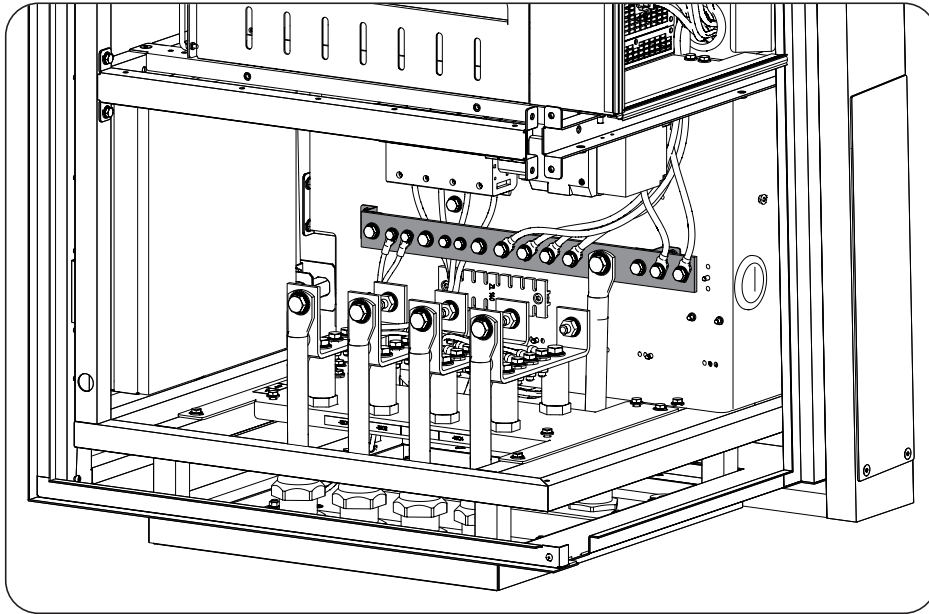

The tightening torque of the different connection points is 60Nm for the phase, neutral and ground cables.

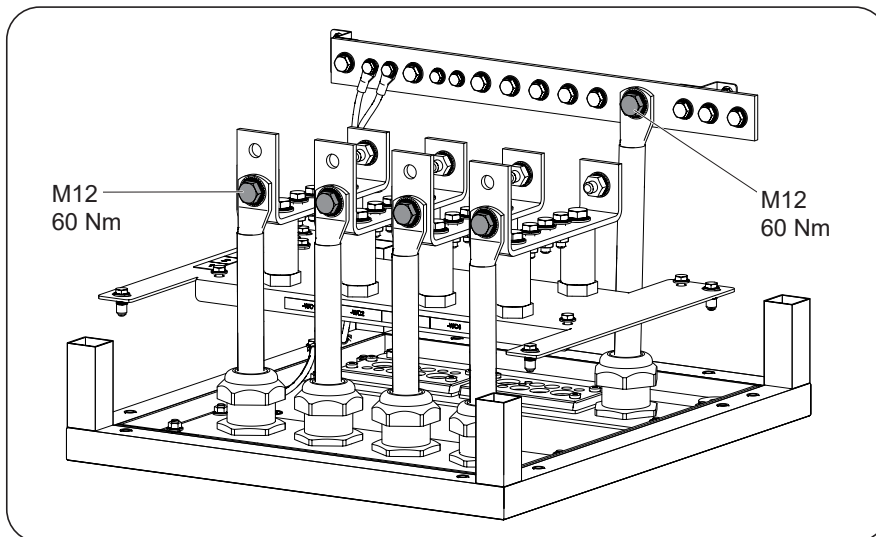

The connection busbars have two connection points to allow the connection of power cables on either of the two points and thus facilitate the connection of cables that are difficult to handle due to their section.

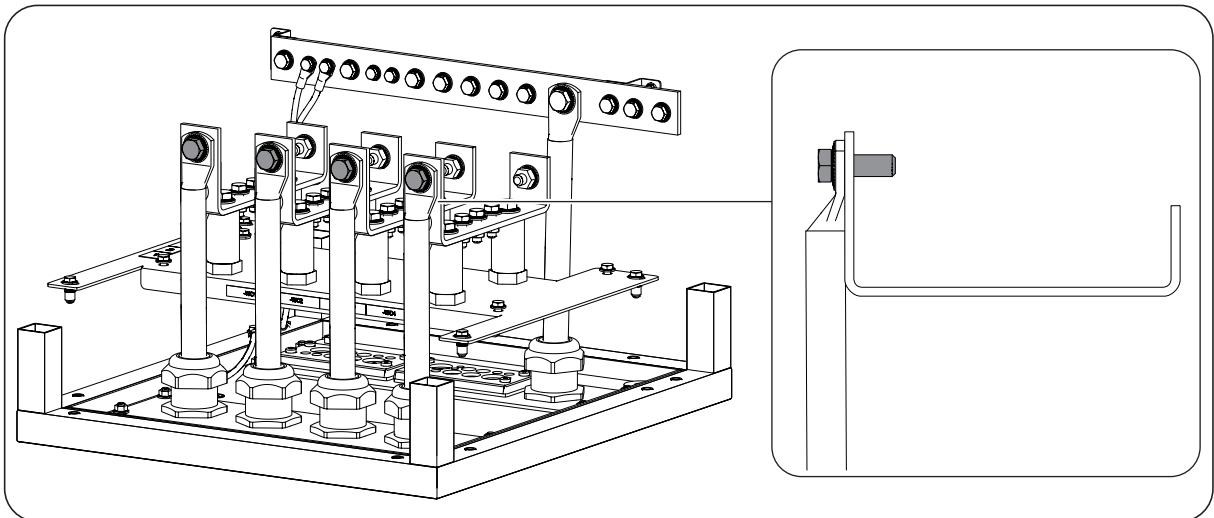
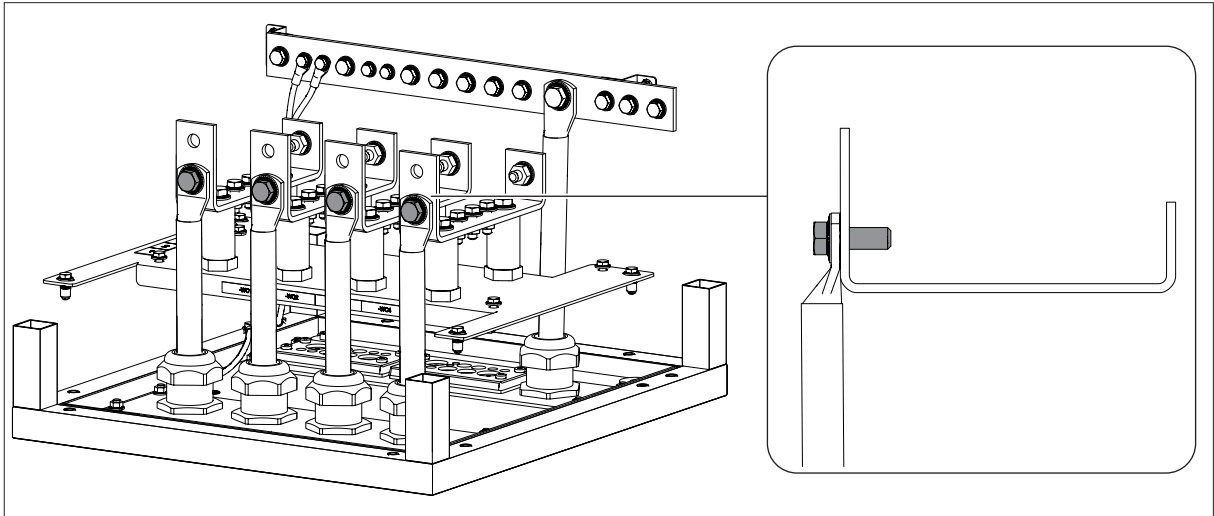

In addition, there is an optional kit that allows the connection of two cables per phase. This kit is not supplied assembled and must be installed by the charger installer. This kit is shown in detail in section [„7.3. Connection kit for two cables“](#).

9. First connection to the electric grid

This chapter details the process for the charger's first connection to the grid.

First review the unit.

9.1. Unit inspection

You must check the correct condition of the installation before start-up.

Each installation is different, depending on its characteristics, the country in which it is located or other special conditions which may apply. In all cases, before starting up, it is necessary to ensure that the installation complies with the applicable legislation and regulations and that at least the part to be started up is complete.

9.1.1. Inspection

Before connecting the charger to the grid for the first time you must carry out a general inspection, which mainly consists of:

Wiring inspection

- Check that the cables are correctly joined to their connectors.
- Check that these cables are in a good condition and that there are no hazards in their environment which damage them, such as sources of intense heat, objects which could cut them or arrangements which put them at risk of impacts or pulling.

Review the unit's fastening

Check that the unit is secured firmly and is not at risk of falling.

9.1.2. Hermetic sealing of the unit

Ensure during installation operations that the unit's level of sealing has not been altered during connection operations.

Check the correct adjustment of the connectors and that any cable grommets are well sealed.

During the installation of the unit, the interface plate can be removed in order to pass the cables. The interface that is shown in the image. However, the cables must be passed through the cable glands and the plate fitted in its position to ensure that the unit is sealed.

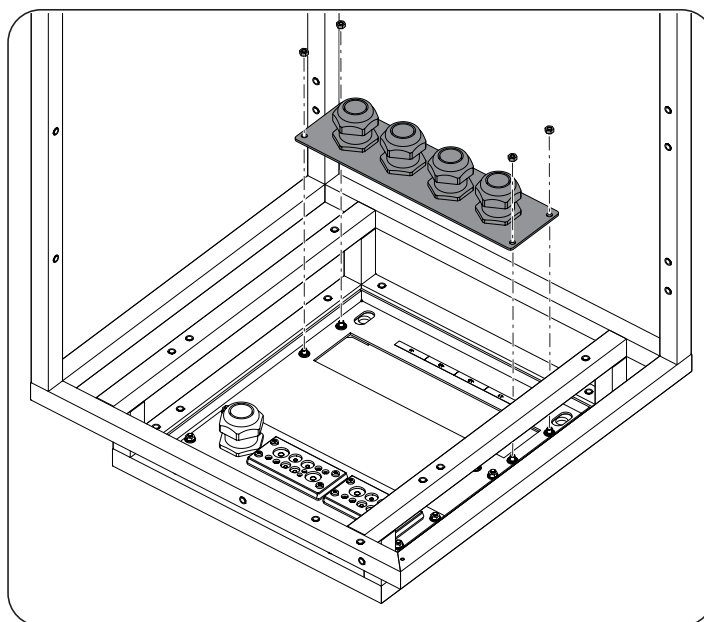

This plate must be fitted before crimping the terminals onto the cables.

10. Shutting down the unit

This section describes the procedure to shut down the unit. If you wish to work inside the unit, you must carry out these instructions in the order shown here to remove the power.

1. If there is an active charge process, finalize the charge session.
2. Press the emergency stop button if the charger has one.
3. Remove AC voltage from a means of disconnection outside the unit.
4. Wait 10 minutes for the internal capacitances to discharge, the hot parts which may cause burns to cool and the fan blades to stop turning.
5. Open the unit and, using the appropriate PPE, check the absence of voltage in the AC input.
6. Signal cut-off point with a sign reading "Caution no switching...". If necessary, rope off the work area.

11. Unit configuration

A local connection is required to configure the unit for the first time. Once this first configuration has been carried out, a remote connection can also be established. The processes for both cases are described below.

The configuration is done through the INGETEAM WEB Manager application.

11.1. Local connection

To establish a local connection the charger and computer must be connected to the same communication network.

The local connection can be done through an Ethernet or Wi-Fi network.

11.1.1. Local connection via Ethernet

CAUTION

The Ethernet cabling must be category 5E or higher.

To make the connection, follow these steps:

1. Connect the computer to the unit using the J13 Ethernet connector.

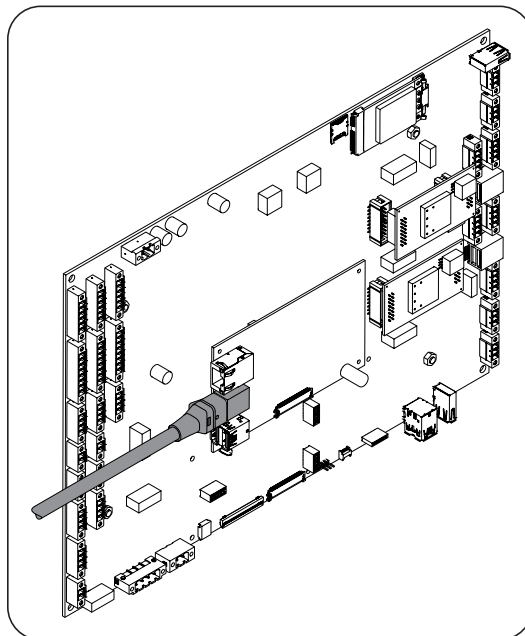

2. On the laptop, open the browser and go to <http://192.168.1.33:8080>.
3. Enter the username and password. The username and password are specified on the sticker attached to the back of the front door.
4. Follow the instructions given by INGETEAM WEB Manager.

CAUTION

If it does not have a public IP, the computer and the charging point will need to be in the same network or APN.

11.2. Remote connection

The purpose of remote connection is to have access to the charger when the charger and the computer are connected to the Internet from different communication networks. The charger must be connected to the Internet via Wi-Fi, Ethernet or 4G.

To make the connection, follow these steps:

1. With the charger and the computer connected to Internet, open the web browser and go to <http://ipChargingStation:8080/> where ipChargingStation is the IP of the charger. Therefore, you will need the IP of the charger.
2. Enter the username and password. The username and password are specified on the sticker attached to the back of the front door.

12. Operation

The main function of the charging station is to supply and measure electrical energy for users that have prior authorization with an RFID card reader system, except in stations configured without authentication.

This section describes the operation of the charging station in detail.

12.1. Status indication

The charging station indicates its current status by means of light signals. It has independent indicators for each power socket.

Status	Lighting	Description
Standby	Continuous green	The charger is operative waiting to be used
Awaiting vehicle connection	Flashing green	The charging station is waiting for a vehicle to be connected in order to proceed with charging
Charging preparation	Flashing blue	The charger is running checks prior to charging with the vehicle connected
Charge	Continuous blue	A vehicle has been connected to the charging station
Ending charge	Flashing blue	The charger is ending the charge
Incident	Continuous red	There is an error in the station or the charging process is not being performed correctly.
Standby	None	The charging station has been disabled/is not operative
Awaiting vehicle disconnection	Flashing green	The charging station is waiting for the vehicle to be disconnected
Software update	Continuous yellow	The unit is updating the software

12.2. User interface

The display screen shows the available stations for selecting the charge.

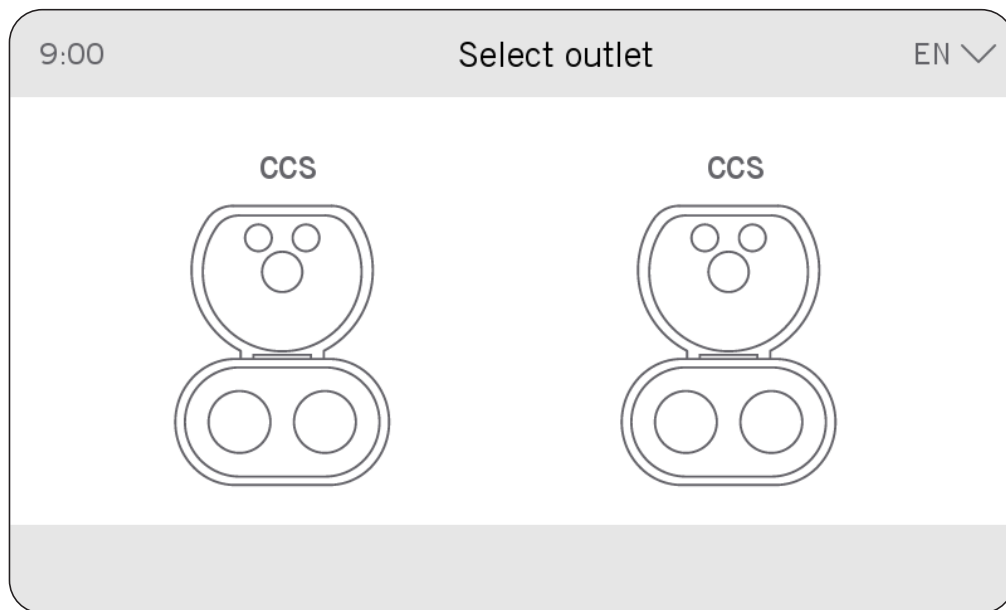

The interface guides the user's charging process.

12.3. Charging process

Depending on the client's requirements, the charging process will start with or without authentication. The process for both cases is described below.

12.3.1. Charging process with authentication

Starting the charge process

1. Check that the charging station is in awaiting vehicle status with the green light on.
2. If you have an ID card, place the card next to the reader located on the area below the display. In the case of a correct reading, the station switches to awaiting charge status. If the charging manager uses an app to manage the charge, follow the instructions on the app to start the process.

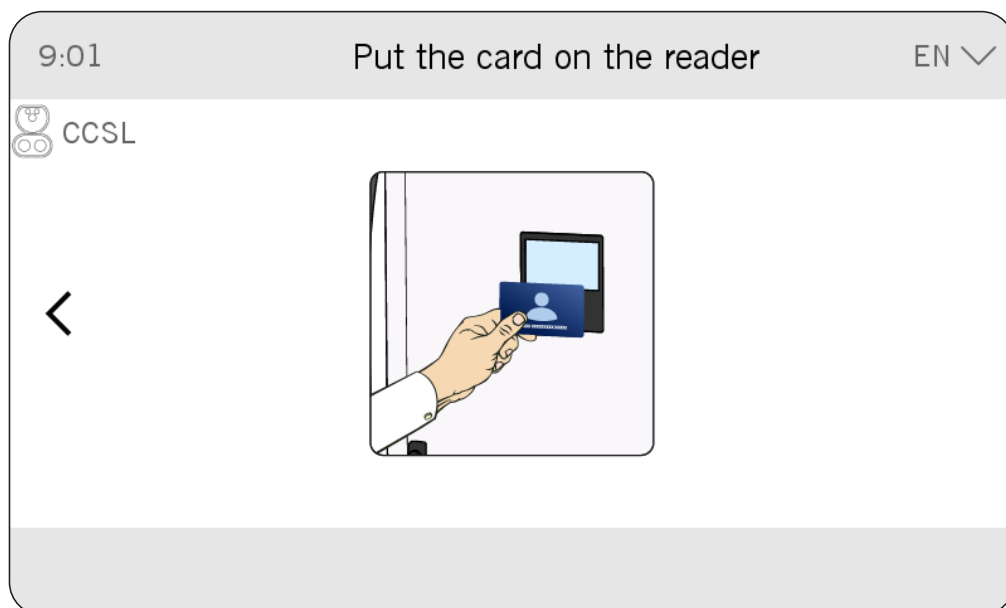

3. Connect the vehicle to the station.

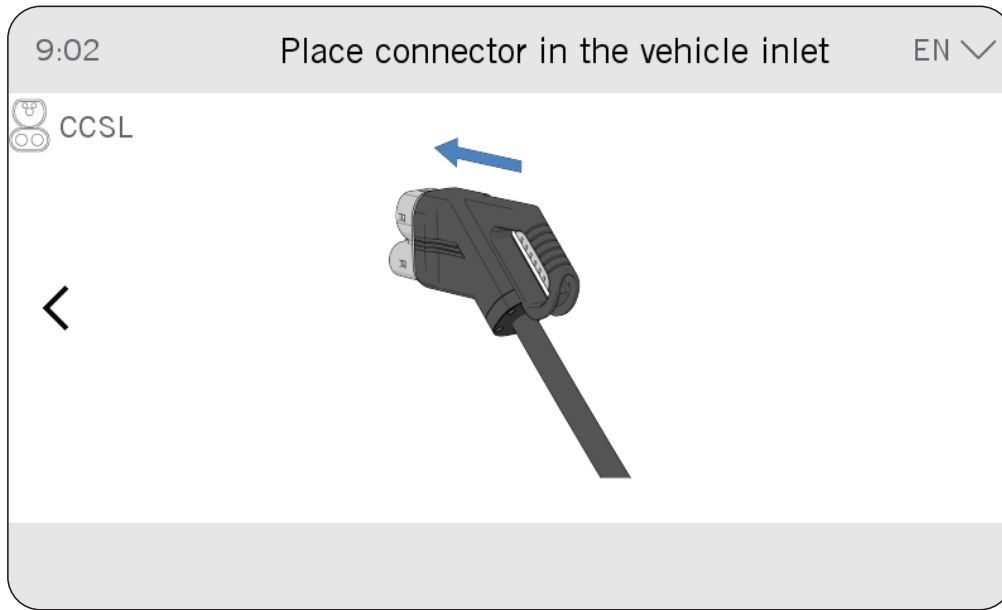

4. The charging starts. The lighting remains blue, fixed if there is consumption and flashing if there is not.

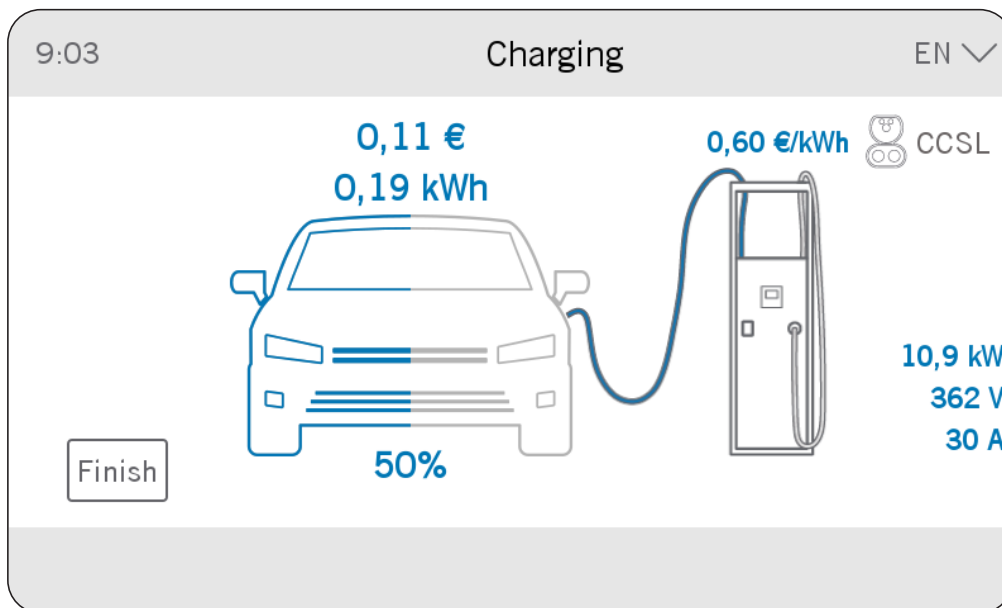

Ending the charge process

1. To end the charging cycle, if you have an ID card, place it against the reader. If the charging is managed through the app, follow the instructions.

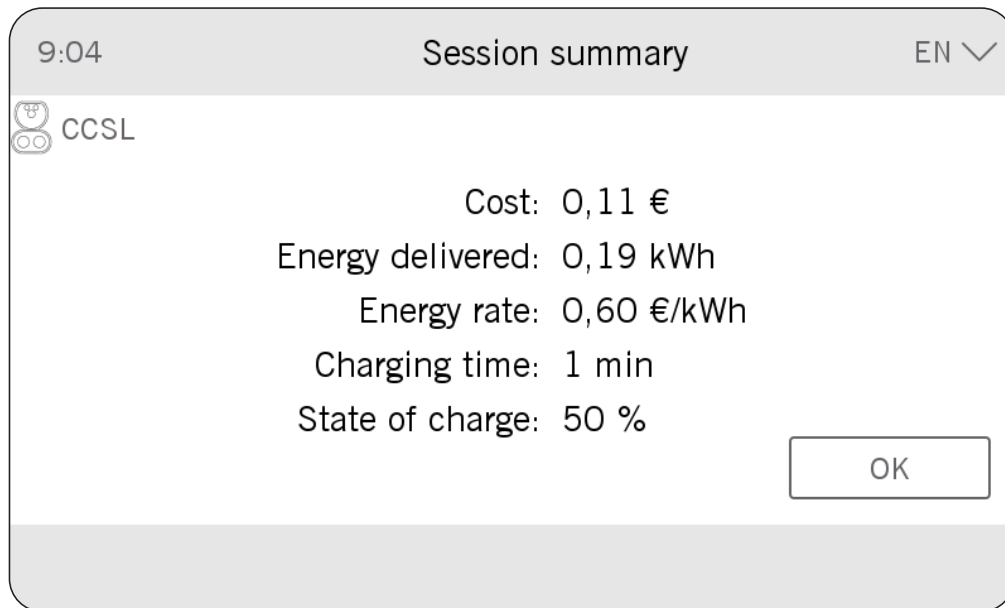

2. Disconnect the vehicle.
3. The charging process stops.

12.3.2. Charging process without authentication**Starting the charge process**

1. Connect the vehicle to the recharging station.
2. The charging starts. The lighting remains blue, fixed if there is consumption and flashing if there is not.

Ending the charge process

1. Disconnect the connector from the vehicle side.
2. The charging process stops.

12.4. Downloading the receipt (Eichrecht certified units)

Charging point operators will permit the receipts stored in their system to be downloaded. For further information, contact the charging point operator.

There may be small differences between the energy data shown on the wattmeter display, visible from the exterior of the charging point, and the energy data registered on the receipt. These differences are due to the fact that, on the display, the accumulated energy value is displayed to two decimal places (10Wh), and the value given for invoicing is only to one decimal place, 1Wh.

13. Maintenance

The maintenance described below lists a series of minimum measures necessary to maintain the charger in good working condition. Please consult Ingeteam preventive and predictive general maintenance if you wish to extend the service life of the charger.

CAUTION

The recommended maintenance tasks must be carried out at least annually, except where otherwise stated.

13.1. Safety conditions

DANGER

All work must be carried out without voltage. If you need to carry out work close to directly accessible live elements, you must do so according to the specifications in a work instruction or similar document.

Keep the doors closed when you are not working in the cubicle.

Keep polycarbonate guards and grilles (protections) in place at all times for elements with directly accessible live parts.

Pay special attention to any parts that may protrude from the unit, such as rods and/or metal edges.

Do not wear rings, chains, watches, baggy clothes, loose hair or any element that may become trapped. Take care when using gloves or cleaning cloths.

In the event of poor lighting, use auxiliary lighting devices.

CAUTION

The entire manual must be read and understood in full prior to manipulating, installing or operating the unit.

Any work carried out that implies a modification of the original electrical arrangements must be proposed and accepted in advance by INGETEAM.

13.2. Condition of hoses and charging connectors

Check the condition of the hoses and connectors. They should not have dents or cuts. Check the proper operation of the connectors.

Check the correct operation of the retractable system. Check that the cable is in good condition and that the pulleys turn smoothly.

Check the condition of the hose holder. Check that the polycarbonate guards are attached and that there is no dirt or damp.

13.3. Condition of the housing

You must carry out a periodical inspection of the condition of the enclosure, verifying the condition of the locks and doors, as well as the anchoring of the units to the ground. In addition, you must check the condition of the housing and the absence of dents or scratches that might degrade the housing or cause it to lose its protection classification. If these types of defect are noticed, the affected parts must be repaired or replaced.

13.4. Condition of cables and terminals

Check that the power circuit connections have the correct tightening torque.

Check that the power cables look in good condition and there are no signs of wear or overheating.

13.5. Cleaning or replacing filters

Remove and clean the filters on the unit ventilation grilles. In the case of damage, replace with new filters.

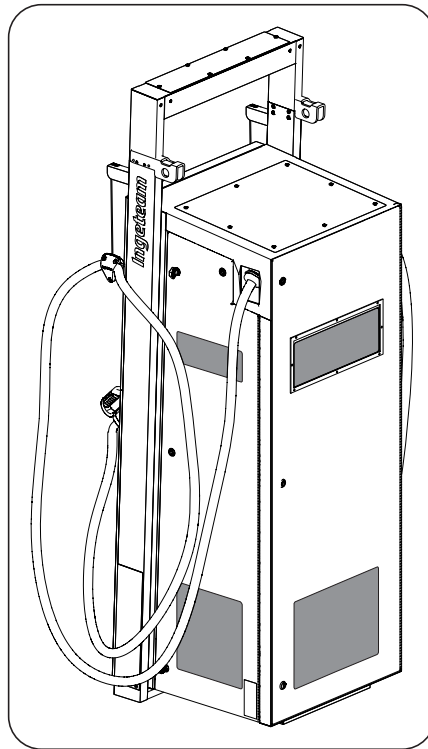

Fig. 8 Air intakes

There are filters in all of the air intakes (both inlets and outlets). These intakes are located on the side and rear doors.

14. Waste handling

Remove and clean the filters on the unit ventilation grilles. In the case of damage, replace with new filters.



At the end of the unit's life, the waste must be correctly processed by an authorized hazardous waste management company.

Ingeteam, in accordance with its policy of respect for the environment, will inform the authorized manager, via this section, of the location of components to be decontaminated.

The elements within the unit that must be handled individually are:

1. Printed circuit board cards.
2. Electrolytic condensers or condensers containing PCB
3. Display.

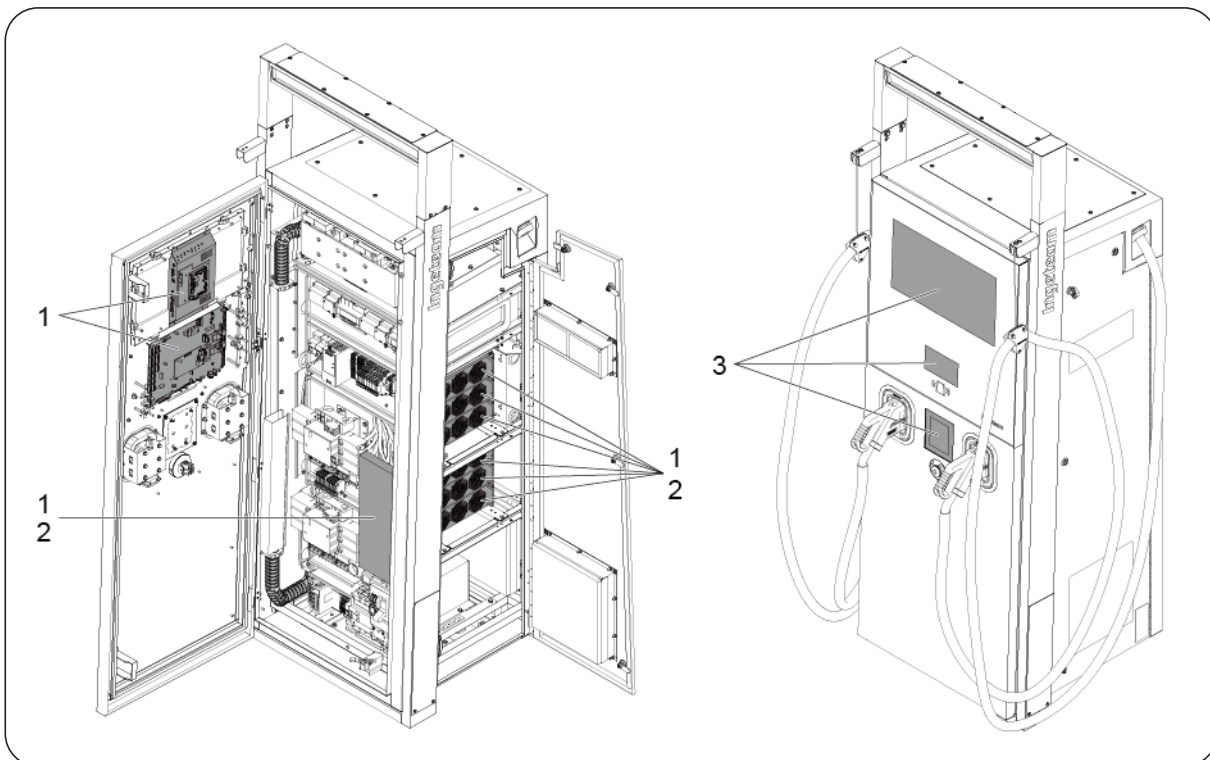

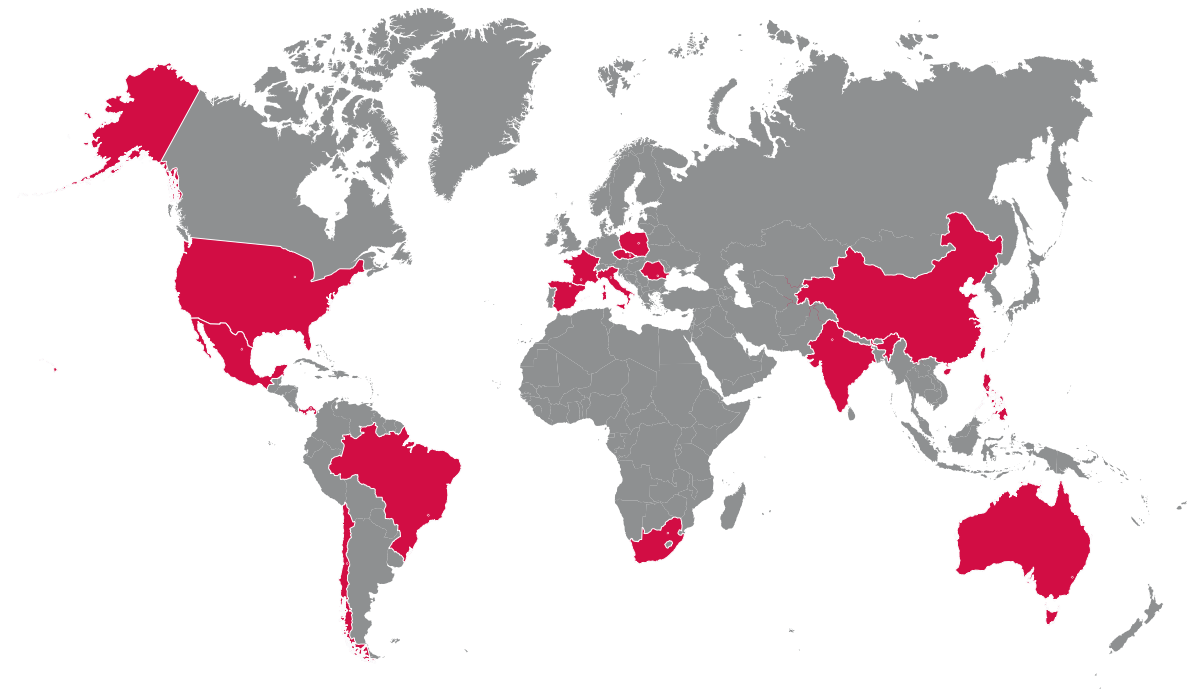

Europe

Ingeteam Power Technology, S.A.

Energy

Avda. Ciudad de la Innovación, 13
31621 SARRIGUREN (Navarra) - Spain
Tel: +34 948 28 80 00
Fax: +34 948 28 80 01
email: solar.energy@ingetteam.com

Ingeteam GmbH

Herzog-Heinrich-Str. 10
80336 MÜNCHEN - Germany
Tel: +49 89 99 65 38 0
Fax: +49 89 99 65 38 99
email: solar.de@ingetteam.com

Ingeteam SAS

Le Naurouze B - 140 Rue Carmin
31676 Toulouse Labège cedex - France
Tel: +33 (0)5 61 25 00 00
Fax: +33 (0)5 61 25 00 11
email: france@ingetteam.com

Ingeteam S.r.l.

Via Emilia Ponente, 232
48014 CASTEL BOLOGNESE (RA) - Italy
Tel: +39 0546 651 490
Fax: +39 054 665 5391
email: italia.energy@ingetteam.com

Ingeteam, a.s.

Technologická 371/1
70800 OSTRAVA - PUSTKOVEC
Czech Republic
Tel: +420 59 732 6800
Fax: +420 59 732 6899
email: czech@ingetteam.com

Ingeteam Sp. z o.o.

Ul. Koszykowa 60/62 m 39
00-673 Warszawa - Poland
Tel: +48 22 821 9930
Fax: +48 22 821 9931
email: polska@ingetteam.com

Ingeteam Service S.R.L.

Bucuresti, Sector 2, Bulevardul Dimitrie
Pompeiu Nr 5-7
Cladirea Hermes Business Campus 1, Birou
236, Etaj 2
Romania
Tel.: +40 728 993 202

America

Ingeteam INC.

3550 W. Canal St.
Milwaukee, WI 53208 - USA
Tel: +1 (414) 934 4100
Fax: +1 (414) 342 0736
email: solar.us@ingetteam.com

Ingeteam, S.A. de C.V.

Ave. Revolución, nº 643, Local 9
Colonia Jardín Español - MONTERREY
64820 - NUEVO LEÓN - México
Tel: +52 81 8311 4858
Fax: +52 81 8311 4859
email: northamerica@ingetteam.com

Ingeteam Ltda.

RuaEstácio de Sá, 560
Jd. Santa Genebra
13080-010 Campinas/SP - Brazil
Tel: +55 19 3037 3773
email: brazil@ingetteam.com

Ingeteam SpA

Los militares 5890, Torre A, oficina 401
7560742 - Las Condes
Santiago de Chile - Chile
Tel: +56 2 29574531
email: chile@ingetteam.com

Ingeteam Panama S.A.

Av. Manuel Espinosa Batista, Ed. Torre
Internacional
Business Center, Apto./Local 407 Urb.C45 Bella
Vista
Bella Vista - Panama
Tel.: +50 761 329 467

Africa

Ingeteam Pty Ltd.

Unit 2 Alphen Square South
16th Road, Randjiespark,
Midrand 1682 - South Africa
Tel: +2711 314 3190
Fax: +2711 314 2420
email: southafrica@ingetteam.com

Asia

Ingeteam Shanghai, Co. Ltd.

Shanghai Trade Square, 1105
188 Si Ping Road
200086 SHANGHAI - P.R. China
Tel: +86 21 65 07 76 36
Fax: +86 21 65 07 76 38
email: shanghai@ingetteam.com

Ingeteam Power Technology India Pvt. Ltd.

2nd floor, 431
Udyog Vihar, Phase III
122016 Gurgaon (Haryana) - India
Tel: +91 124 420 6491-5
Fax: +91 124 420 6493
email: india@ingetteam.com

Ingeteam Philippines Inc.

Office 2, Unit 330, Milelong Bldg.
Amorsolo corner Rufin St.
1230 Makati
Gran Manila - Philippines
Tel.: +63 0917 677 6039

Australia

Ingeteam Australia Pty Ltd.

iAccelerate Centre, Building 239
Innovation Campus, Squires Way
NORTH WOLLONGONG, NSW 2500 - Australia
Tel.: +61 499 988 022
email: australia@ingetteam.com

ACA2011IQM01_C
03/2024

Ingeteam