

MV SOLUTION UP TO 8.4 MVA.

A MEDIUM VOLTAGE STATION FOR VIRTUAL CENTRALIZED BES SYSTEMS WITH 1,500 V STRING INVERTERS

MV station designed to connect and hold Ingeteam's three-phase string inverters working as an interface with the grid.

String inverter optimization

The StringStation has been conceived to enable and optimize the use of Ingeteam's INGECON® SUN STORAGE 350TL inverters, ensuring a perfect connection between the BESS plant and the grid. This turnkey solution is capable of connecting up to 8.4 MW of 1,500 V 3Play inverters to a medium voltage grid.

Available worldwide

The INGECON® SUN Virtual Central Station can be marketed and installed everywhere in the world, as it is supplied totally integrated and it is easily transportable as a Plug & Play solution.

Equipped with everything necessary

It is supplied with the low-voltage string-inverter protections, auxiliary services, LV / MV transformer and medium-voltage switchgear.

Maximum cost-effectiveness

The INGECON® SUN Virtual Central Station is a standard solution designed to maximize the compactness and cost-effectiveness of the overall equipment. All the elements are prepared to withstand adverse weather conditions. Moreover, they are supplied pre-connected and preintegrated into a skid in order to guarantee a Plug & Play installation.

A medium voltage string station for virtual centralized BES systems which allows flexibility and scalability

Main features

- Output power up to 8.4 MW.
- Compatible with INGECON® SUN STORAGE 350TL inverters.
- Available up to 33 kV output voltage.
- Available with outdoor-mounted hermetically-sealed LV / MV transformer.
- IP54 MV Switchgear.
- Plug & Play solution.

AC Combiner Box

- Scalable system thanks to its modular design.
- Circuit breaker protection per each AC Combiner Box.
- 1500 V DC fuses.
- Forced air ventilation.

Standard MV equipment

- LV / MV transformer with reduced power losses.
- LC MV switchgear.
- DGPT2 relay included in the transformer.
- MV protection with circuit breaker.
- Oil deposit integrated in the skid.
- Filtering kit in the oil deposit.

Benefits

- Maximum reliability, higher safety.
- Reduced maintenance.
- Flexibility and scalability.
- Greater power density.



AC quick connectors.

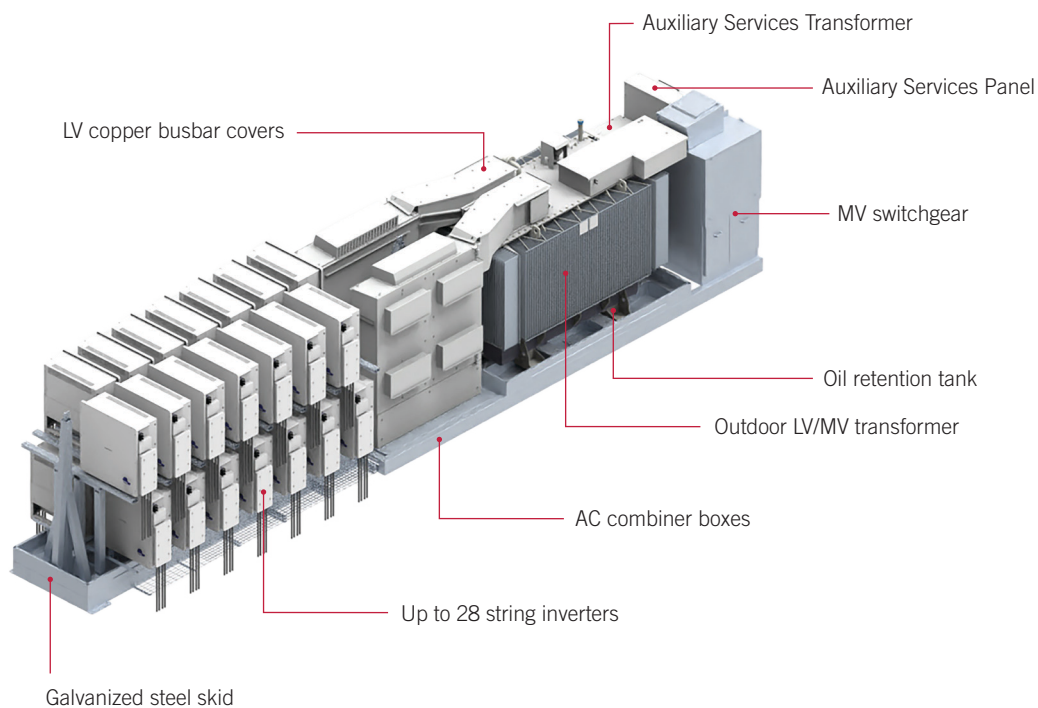

VCST 8400

AC COMBINER BOX

Rated power at 40 °C	8,400 kW
Number of inverters	28
AC current at 40 °C	7,000 A
AC voltage	690 V
Frequency	50 / 60 Hz
Overcurrent protection	Circuit breaker
Cooling system	Forced air ventilation
Protection degree	IP54
Maximum aux. consumption	2.3 kW

LV / MV TRANSFORMER

Type	Oil-immersed hermetically sealed transformer
Medium voltage	Up to 33 kV
Cooling system	ONAN
Max. efficiency	99%
Protection degree	IP54

MV SWITCHGEAR

Type	RLC (bus riser, line incoming with disconnecting switch, transformer protection)
Medium voltage	Up to 33 kV (class 36 kV)
Rated current	630 A
Protection degree	IP54

GENERAL DATA

Operating temperature range	From -20°C to +50°C
Relative humidity (non-condensing)	0-100%
Maximum altitude	4,000 masl (for instalations beyond 1,000 masl, please contact Ingeteam's Sales Department)

EQUIPMENT

Inverter version	INGECON® SUN STORAGE 350TL
------------------	----------------------------

MECHANICAL INFORMATION

Structure type	Hot dip galvanized skid
Body dimensions (W x D x H)	11,650 x 2,134 x 2,560 mm
Weight	30.5 ton
Standards	IEC 60076, IEC 62271-200

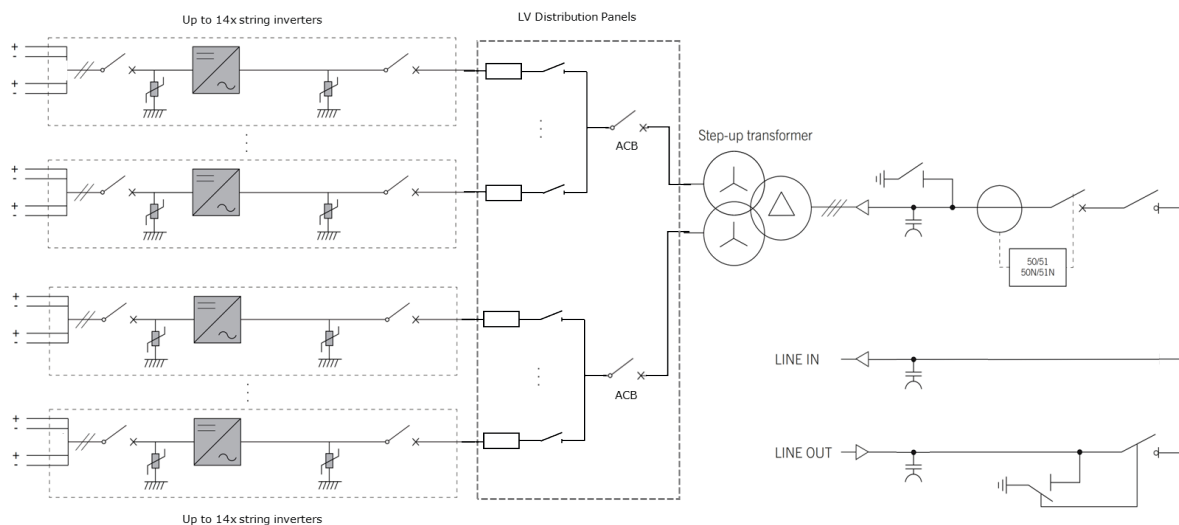

Specifications included in this datasheet could change without notice. Please contact Ingeteam's sales department in case of any queries.

INGECON SUN STORAGE VCST 8400_EN_RV_A4

EUROPE

Ingeteam Power Technology, S.A.
Avda. Ciudad de la Innovación, 13
31621 Sarriguren (Navarra) - Spain
Tel.: +34 948 288 000
Fax: +34 948 288 001
e-mail: evc.energy@ingeteam.com

Ingeteam S.r.l.
Via Emilia Ponente, 232
48014 Castel Bolognese (RA) - Italy
Tel.: +39 0546 651 490
Fax: +39 054 665 5391
e-mail: emobility.italia@ingeteam.com

Ingeteam SAS
140 Rue Carmin - Le Naurouze B
31670 Labège - France
Tel.: +33 (0)5 61 25 00 00
Fax: +33 (0)5 61 25 00 11
e-mail: france@ingeteam.com

Ingeteam, a.s.
Technologická 371/1
70800 Ostrava - Pustkovec
Czech Republic
Tel.: +420 59 747 6800
Fax: +420 59 732 6899
e-mail: czech@ingeteam.com

Ingeteam GmbH
Grand Bateau – Zollhof 6
D-40221 – Düsseldorf, Germany
Tel.: +49 (0) 211 78177950
e-mail: deutschland@ingeteam.com

Ingeteam Poland Spzoo
Ul. Koszykowa 60/62 m 39
00-673, Warsaw, Poland
Tel.: (+48) 22 821 99 30
e-mail: polska@ingeteam.com

Ingeteam LTD.

Unit 10 Gordano 19, Garanor Way, Portbury
Bristol, BS20 TXE - United Kingdom
Tel.: +44 (0) 331 630 0305

NORTH AMERICA

Ingeteam Inc.
3550 W. Canal St.
Milwaukee, WI 53208 - USA
Tel.: +1 (414) 934 4100 / +1 (855) 821 7190
Fax: +1 (414) 342 0736
e-mail: usa@ingeteam.com

Ingeteam Power Technology México S de RL de CV
Av. Ejército Nacional Mexicano 351,
Chapultepec Morales, Granada,
Miguel Hidalgo,
CP: 11520
Ciudad de México, CDMX
Tel.: (+52) 55 6586 9930
e-mail: proveedores.iptm@ingeteam.com

SOUTH AMERICA

Ingeteam Ltda.
Rua Estácio de Sá, 560
Santa Genebra
Campinas - SP
CEP: 13080-010; São Paulo - Brazil
Tel.: (+55) 19 30 37 37 73
e-mail: brazil@ingeteam.com

Ingeteam Chile SpA
Balmoral n.º 309, Piso 10º, Oficina 1008,
7561282 Las Condes
Santiago, Chile
Tel.: (+56) 229 253 825
e-mail: chile@ingeteam.com

ASIA

Ingeteam Power Technology Shanghai, Co. Ltd.
Room 2606-F, No.360 South Pudong Road
China (Shanghai) pilot free trade zone
C.P 200120
Tel.: +86 139 1622 4886
e-mail: liu.yimin@ingeteam.com

Ingeteam India Pvt. Ltd.
Survey No. 111/1-111/3 & 111/5-111/7,
Village No.155, Mambakkam Village,
Chennai - Bangalore Main Road,
Sriperumbudur Taluk,
Kancheepuram District - 602106,
Tamilnadu, India

Ingeteam Power Technology S.A. UAE Branch
Al Bateen tower c6 Bainunah 1st floor
Street 34
Abu Dhabi - UAE
Tel.: +971 2 207 6666

Ingeteam Power Technology S.A.
Thailand representative office
100/67 Vongvanij B Building, 22nd floor,
Rama IX Road., HuayKwang,
10320 Bangkok
Te.: +66 22461798
e-mail: Thailand.pga@ingeteam.com

AUSTRALIA

Ingeteam Australia Pty Ltd.
Iaccelerate Centre, Building 239
Innovation Campus, Squires Way
North Wollongong, NSW 2500 - Australia
Tel.: +61 429 111 190
e-mail: australia@ingeteam.com

Ingeteam

www.ingeteam.com